

12052
Pigeonite Basalt
1866 grams

Revised



Figure 1: Photo of broken side of 12052 showing vugs. Sample is 6.5 cm high. NASA # S70-44633.

Summary of Age Data for 12052

	Ar/Ar	Rb/Sr	Nyquist 1977 (recalculated)
Murthy et al. 1971		2.92 ± 0.18 b.y.	
Compston et al. 1971		3.28 ± 0.19	(3.22 ± 0.19)

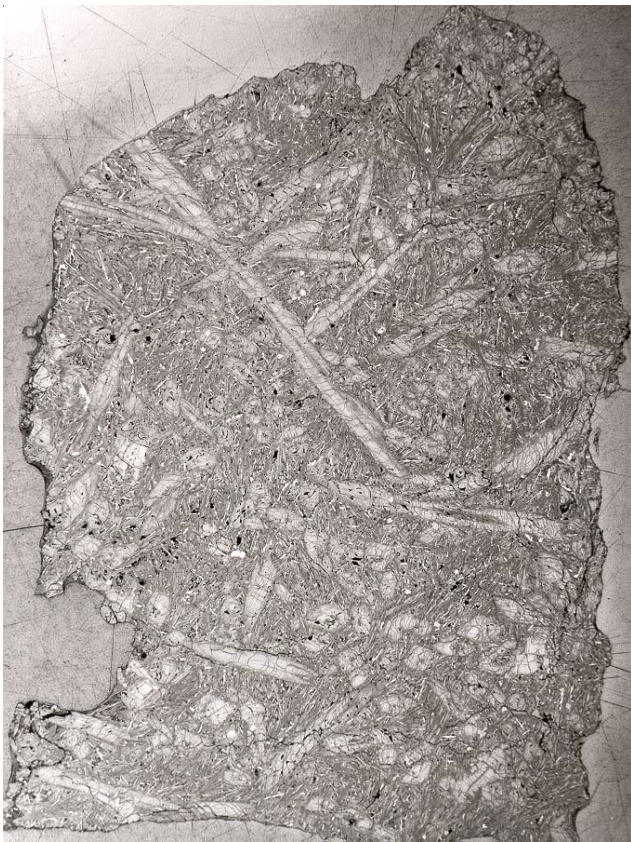

Figure 2a: Reflected light photo of thin section 12052,6. Scale about 3 cm. NASA #S70-30232.



Figure 2b: Transmitted light photo of thin section 12052,6. NASA #S70-25409.

Introduction

12052 is a porphyritic pigeonite basalt about 3.2 b.y old. It was rounded and covered with zap pits on all sides, before it was broken (figures 1 and 9).

Petrography

Bence et al. (1970) reported that 12052 is composed of “euhedral and skeletal phenocrysts of olivine and clinopyroxene (pigeonite cores with augite rims) surrounded by a groundmass including high-iron clinopyroxene, chrome spinel, ilmenite, pyroxferroite and anorthite”. Bence et al. (1971) described the rock as “porphyritic” with variolitic groundmass (figures 2

and 3). Champness et al. (1971) explain that “this rock consists of elongated phenocrysts of pyroxene (3-4 mm) in random orientation, together with skeletal or rounded olivine crystals (1 mm) in a finer-grained variolitic groundmass of pyroxene-plagioclase and opaques minerals, chiefly ilmenites, which are parallel to the pyroxene laths.”

Mineralogy

Olivine: Champness et al. (1971) report olivine is Fo₇₁,

58.

Pyroxene: Bence et al. (1970, 1971) studied the complex zoning patterns in the large pyroxenes in 12052. Pigeonite cores have sharp boundaries with augite rims (figure 4). Pyroxene

Mineralogical Mode for 12052

	Neal et al. 1994	Papike et al. 1976	Champness et al. 1971
Olivine	1	3.9	5
Pyroxene	57.9	68.1	
Plagioclase	31.7	17.2	
Opaques		10.8	7
Ilmenite	3.5		
Chromite +Usp	2.5		
mesostasis	3		
“silica”			trace

Figure 3,a,b: Photomicrographs of thin section 12052,7 showing zoned pyroxene phenocrysts in cross section and variolitic groundmass. Scale is about 2.5 mm across. NASA #S 70-49562-563.

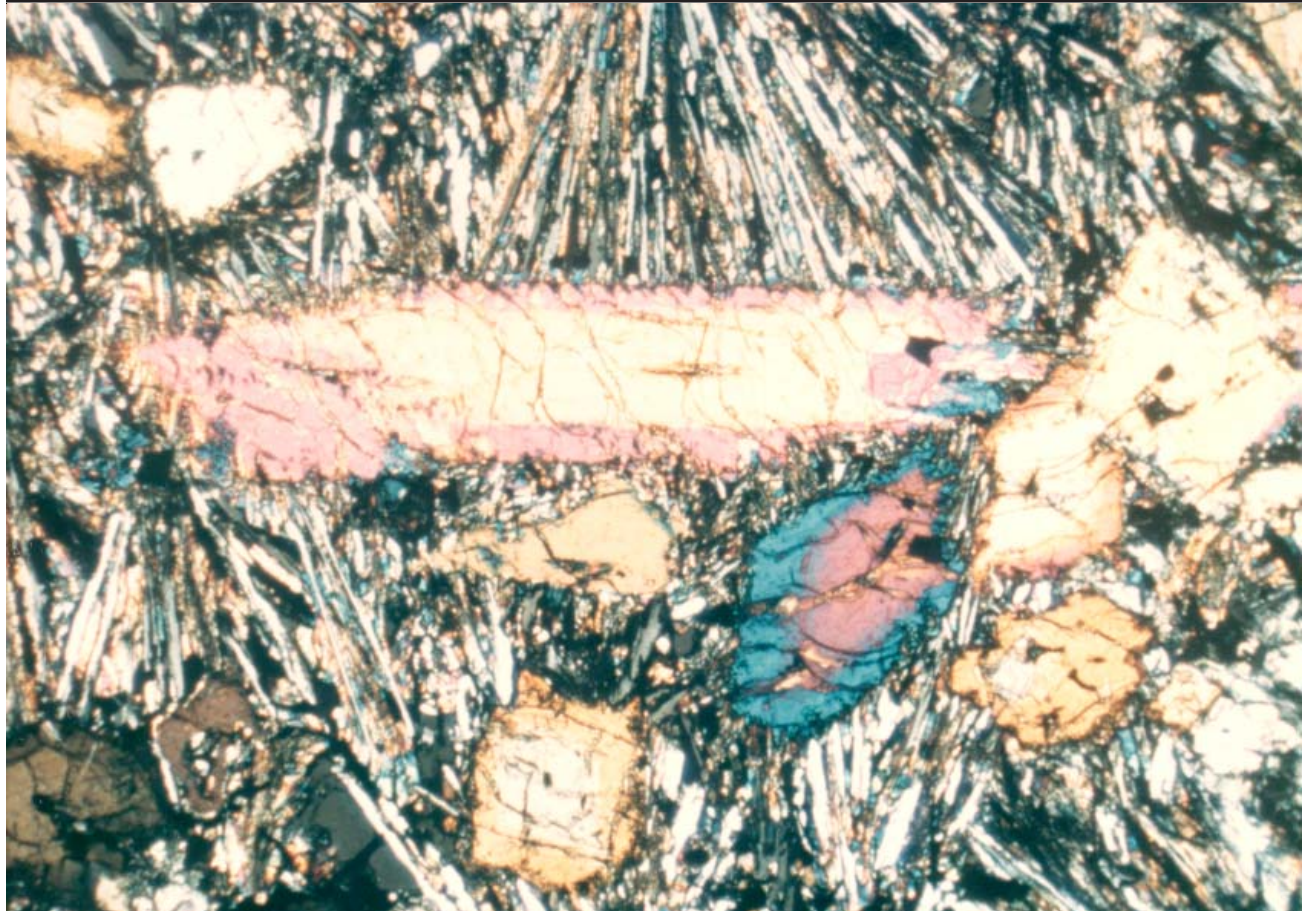
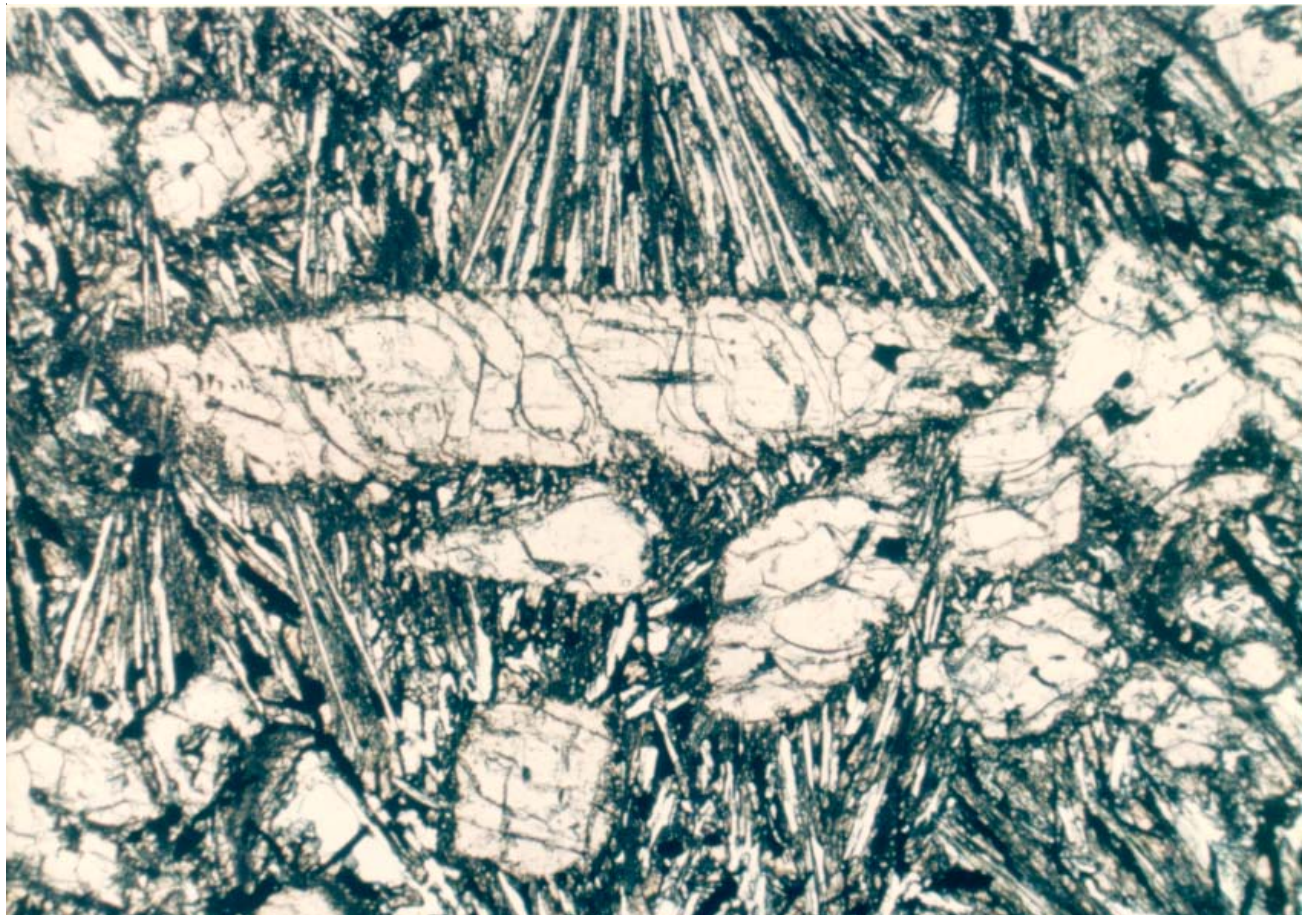

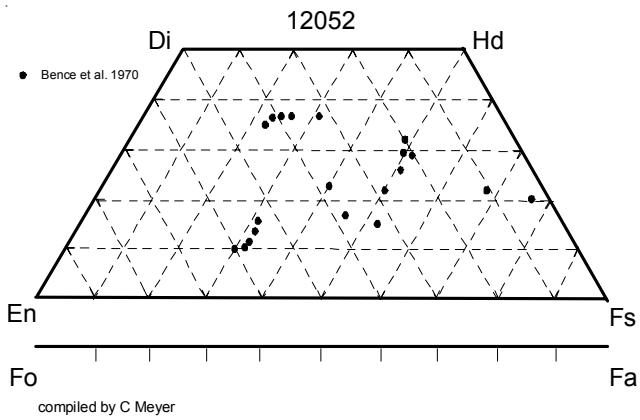

Figure 4: Bence et al. (1970, 1971) determined the composition of pyroxene in 12052.

rim and groundmass pyroxene is increasingly Fe-rich. Papike et al. (1971) and Takeda (1971) reported crystallographic data and discussed epitaxy and exsolution of pyroxenes in 12052. Champness et al. (1971) used high-voltage TEM to study fine structure (exsolution).

Plagioclase: Plagioclase crystals in 12052 are narrow (55 microns) (Baldrige et al. 1979).

Ilmenite: Ilmenite in 12052 occurs as lath-shaped crystals up to 400 micron long and 50 micron wide, typically found intergrown with plumose plagioclase-pyroxene aggregates of the groundmass (Gibb et al. 1970).

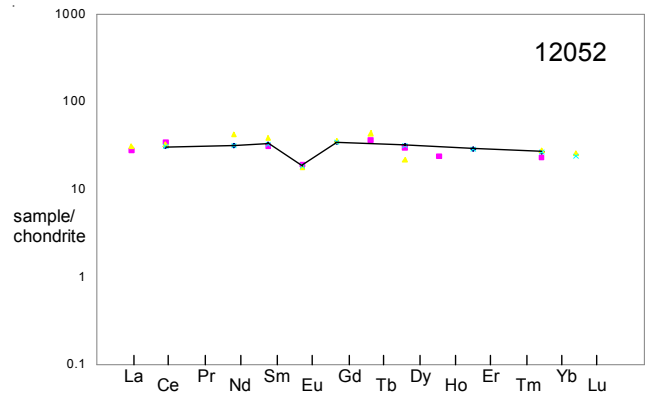

Figure 5: Normalized rare-earth-element diagram for 12052 (data from Wanke et al. connected).

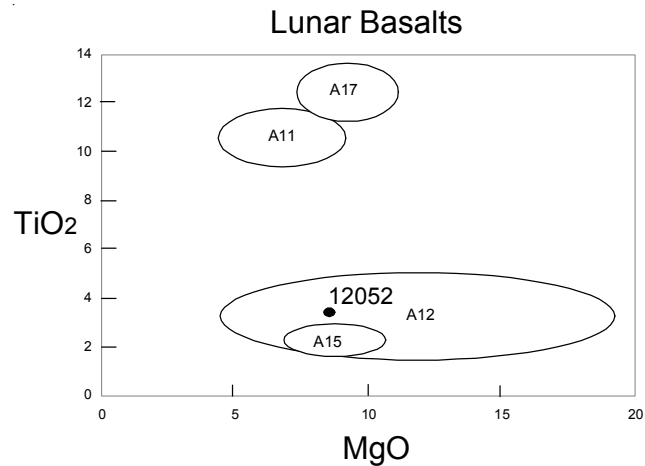

Figure 6: Composition of 12052 compared with that of other lunar basalts.

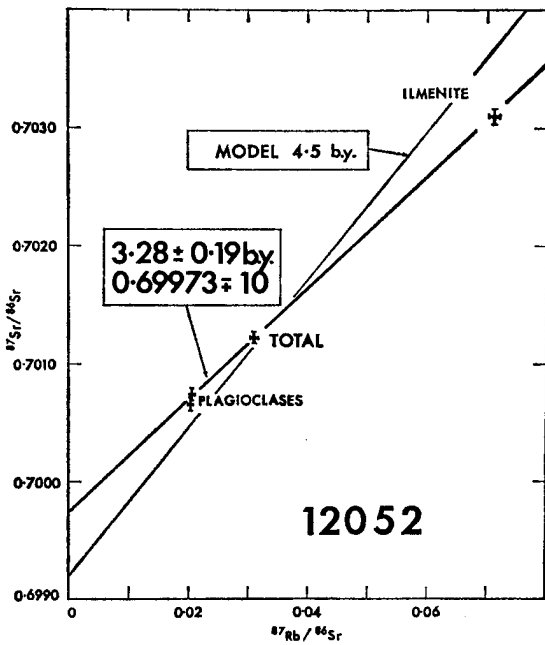

Figure 7: Rb/Sr isochron diagram for 12052 (from Compston et al. 1971).

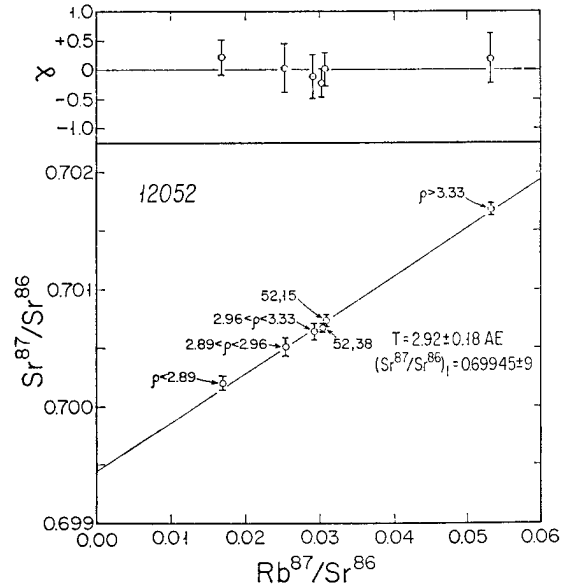

Figure 8: Rb/Sr isochron for 12052 (from Murthy et al 1971).

Table 1a. Chemical composition of 12052.

reference weight	Maxwell71	Kushiro71 1 g	LSPET70	Murthy71		O'Kelly71 201 g	Wanke71	Schnetzler71 204 mg	Compston71	
SiO ₂ %	46.59	46.49 (f)	42 (c)				47.3 (a)		46.13 (g)	
TiO ₂	3.3	3.18	3.6				2.5 (a)		3.35 (g)	
Al ₂ O ₃	10.24	10.29	11				10.1 (a)		9.95 (g)	
FeO	19.82	19.93	21				19.6 (a)		20.7 (g)	
MnO	0.258	0.27	0.31				0.28 (a)		0.28 (g)	
MgO	8.14	8.44	10				8.46 (a)		8.07 (g)	
CaO	10.7	10.82	11				11.9 (a)		10.89 (g)	
Na ₂ O	0.27	0.28	0.45				0.24 (a)		0.26 (g)	
K ₂ O	0.067	0.07	0.069	0.054	0.058 (d)	0.065 (e)	0.067 (a)	0.064 (d)	0.071 (g)	
P ₂ O ₅	0.083	0.03							0.08 (g)	
S %									0.07 (g)	
sum										
Sc ppm	52.3 (b)		52				50.6 (a)			
V	160 (b)		105						149 (g)	
Cr	3675 (b)	3763	3700				3490 (a)		3140 (g)	
Co	42 (b)		42				38.4 (a)		34 (g)	
Ni	23 (b)		32				39 (a)		6 (g)	
Cu	16 (b)						39 (a)		8 (g)	
Zn									9 (g)	
Ga							3.9 (a)		2.1 (g)	
Ge ppb							60 (a)			
As							0.006 (a)			
Se										
Rb			0.8	1.12	1.26 (d)			1.26 (d)	1.22 (g)	1.26 (d)
Sr	85 (b)		135	105	110 (d)		110 (a)	116 (d)	113.7 (g)	113.8 (d)
Y	48 (b)		42						40 (g)	
Zr	150 (b)		170						121 (g)	
Nb									7 (g)	
Mo										
Ru										
Rh										
Pd ppb										
Ag ppb										
Cd ppb										
In ppb							7.8 (a)			
Sn ppb										
Sb ppb										
Te ppb										
Cs ppm										
Ba			50	66	69 (d)		70 (a)	75 (d)	70 (g)	
La	7.4 (a)						6.52 (a)		5 (g)	
Ce	20 (a)						21 (a)	18.8 (d)	12 (g)	
Pr										
Nd	19.5 (a)							14.7 (d)		
Sm	5.8 (a)						4.5 (a)	4.91 (d)		
Eu	1.01 (a)						1.08 (a)	1.04 (d)		
Gd	7.1 (a)							6.87 (d)		
Tb	1.62 (a)						1.35 (a)			
Dy	5.3 (a)						7.44 (a)	7.74 (d)		
Ho							1.34 (a)			
Er								4.55 (d)		
Tm	0.72 (a)									
Yb	4.5 (a)						3.7 (a)	4.32 (d)		
Lu	0.64 (a)						0.58 (a)	0.651 (d)		
Hf	3.1 (a)						3.8 (a)			
Ta	0.77 (a)						0.44 (a)			
W ppb							150 (a)			
Re ppb										
Os ppb										
Ir ppb							3.6 (a)			
Pt ppb										
Au ppb							0.9 (a)			
Th ppm						1.03 (e)	1.28 (a)			
U ppm						0.27 (e)	0.356 (a)			

technique: (a) INAA, (b) OES, (c) , (d) IDMS, (e) radiation counting, (f) conventional wet, (g) XRF, (h) SSMS

Table 1b. Chemical composition of 12052.

reference	Taylor71	Tatsumoto71
weight		
SiO ₂ %		
TiO ₂		
Al ₂ O ₃		
FeO		
MnO		
MgO		
CaO		
Na ₂ O		
K ₂ O		
P ₂ O ₅		
S %		
sum		
Sc ppm	54	(h)
V	160	(h)
Cr	3300	(h)
Co	42	(h)
Ni	21	(h)
Cu	5	(h)
Zn		
Ga		
Ge ppb		
As		
Se		
Rb		
Sr	110	(h)
Y	48	(h)
Zr	130	(h)
Nb	6	(h)
Mo	0.03	(h)
Ru		
Rh		
Pd ppb		
Ag ppb		
Cd ppb		
In ppb		
Sn ppb	0.16	(h)
Sb ppb		
Te ppb		
Cs ppm	0.03	(h)
Ba	65	(h)
La	6.3	(h)
Ce	21	(h)
Pr	2.6	(h)
Nd	17	(h)
Sm	6.3	(h)
Eu	0.9	(h)
Gd	9	(h)
Tb	2	(h)
Dy	9.6	(h)
Ho	2.7	(h)
Er	7.2	(h)
Tm	1.1	(h)
Yb	5.3	(h)
Lu		
Hf	4.6	(h)
Ta		
W ppb		
Re ppb		
Os ppb		
Ir ppb		
Pt ppb		
Au ppb		
Th ppm	1.15	(h) 1.282 1.231 1.411 (d)
U ppm	0.3	(h) 0.365 0.347 0.404 (d)

technique: (a) INAA, (b) OES, (c) , (d) IDMS, (e) radiation counting, (f) conventional wet, (g) XRF, (h) SSMS

Chromite-ulvöspinel: Gibb et al. (1970) determined the composition of Al-chromite cores and Ti-ulvöspinel rims.

Iron: Champness et al. (1971) report about 2 % Ni and 1.5 % Co in metallic iron grains.

Chemistry

The major element composition was determined by Maxwell and Wiik (1971), Kushiro et al. (1971) and Compston et al. (1971). Trace elements were determined by Taylor et al. (1971), Wanke et al. (1971) and Schnetzler et al. (1971)(figure 5).

Radiogenic age dating

Murthy et al. (1971) determined a Rb-Sr mineral isochron with age 2.92 ± 0.18 b.y. (figure 8) and Compston et al. (1971) determined 3.28 ± 0.19 b.y. (figure 7).

Cosmogenic isotopes and exposure ages

Burnett et al. (1975) determined an exposure age of 230 ± 40 m.y. by $^{81}\text{Kr}/^{83}\text{Kr}$ and Marti and Lugmair (1971) determined 129 ± 7 m.y. by $^{81}\text{Kr}/^{83}\text{Kr}$. Hintenberger et al. (1971) also determined exposure ages for 12052 using ^3He (120 m.y.), ^{21}Ne (140 m.y.) and ^{38}Ar (130 m.y.).

Other Studies

Bogard et al. (1971) and Hintenberger et al. (1971) reported the content and isotopic composition of rare gases in 12052.

Processing

A large amount of 12052 was used for the biopool sample.

List of Photo #s for 12052

S69-62806 – 62819	
S69-63832 – 63834	
S70-44847 – 44848	12052,1
S70-44630 – 44639	12052,2
S70-49562 – 49563	TS color
S70-49835 – 49836	TS color
S70-17972 – 17973	TS color
S75-34165 – 34170	mug color
S75-34269	sawing
S75-34255 – 34257	saw cut

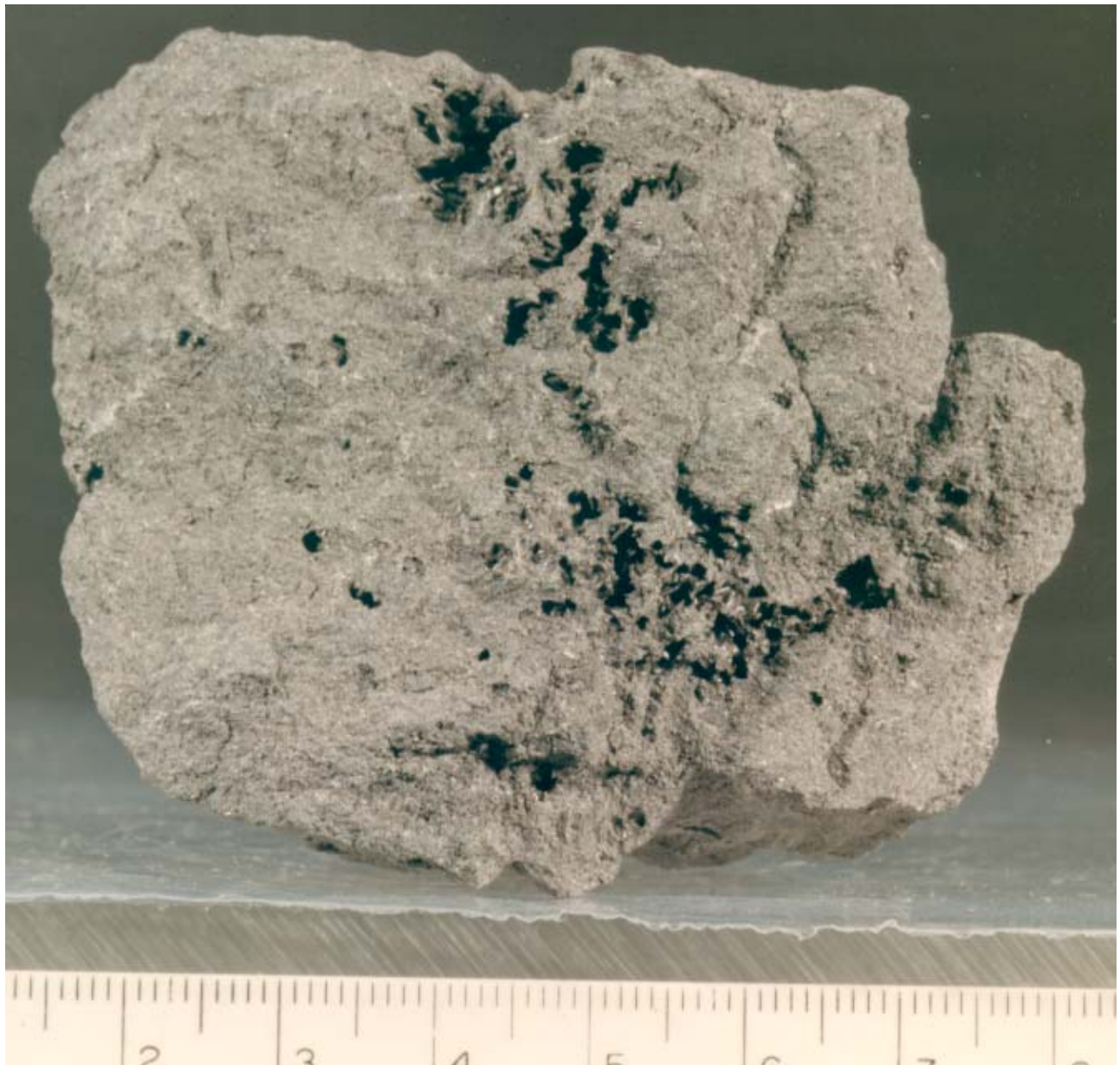
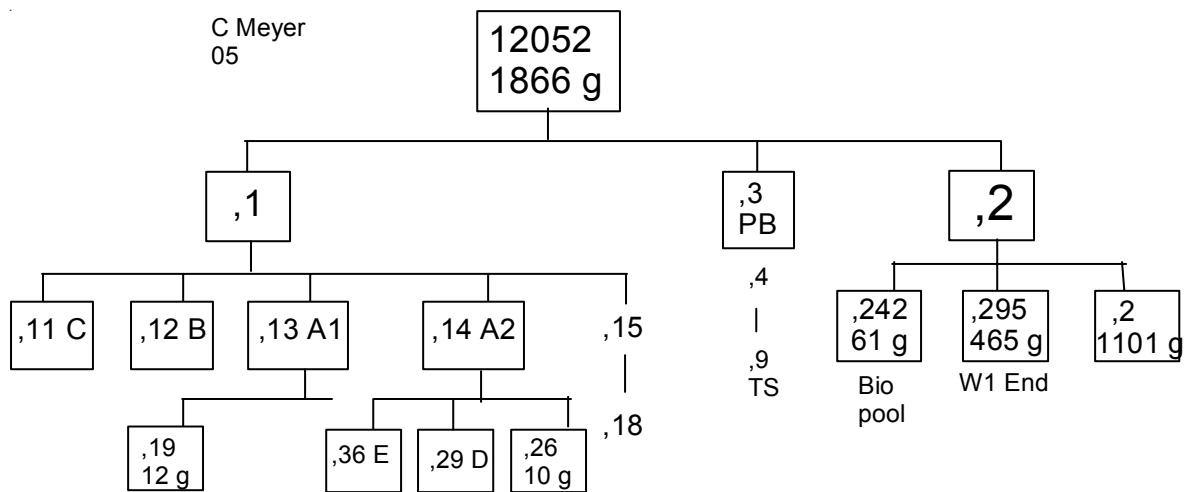
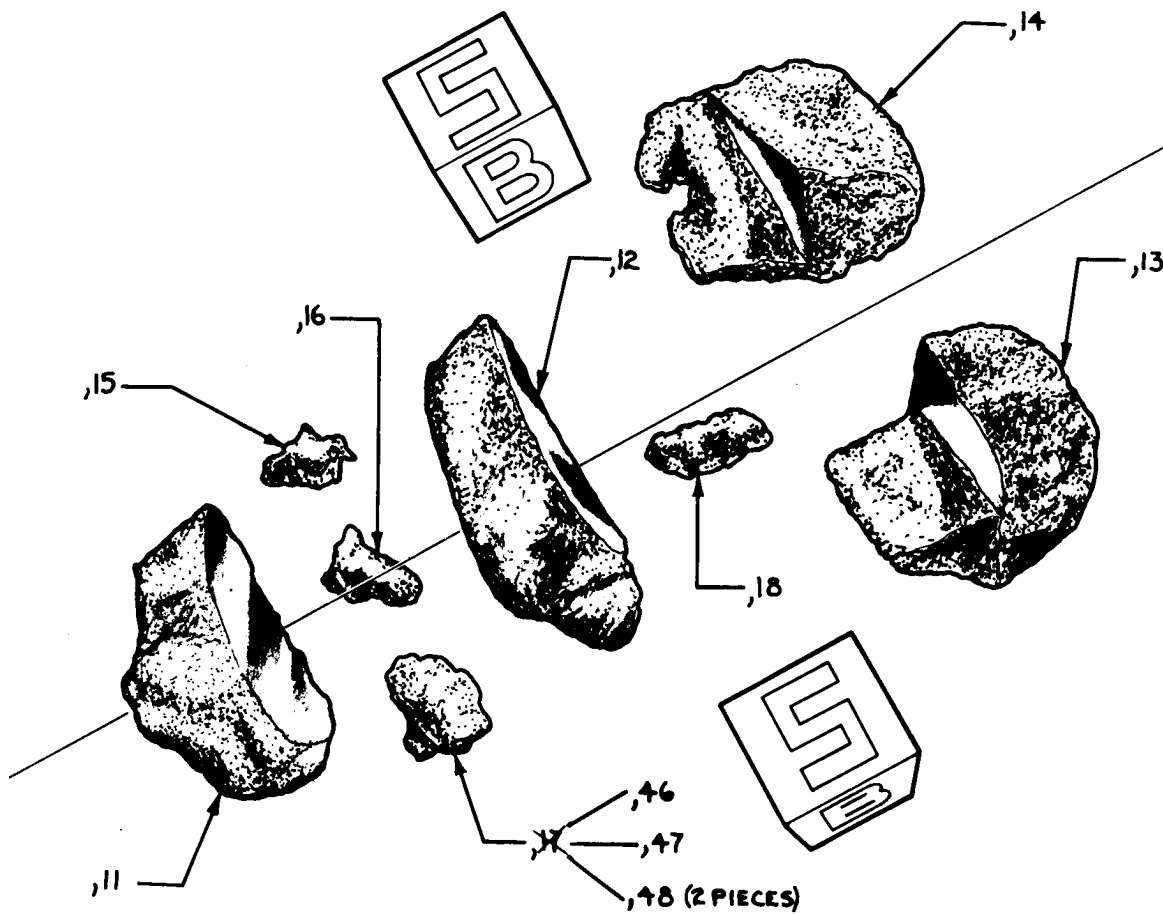
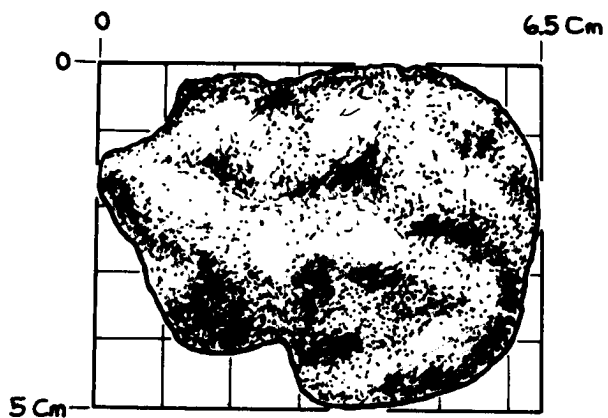
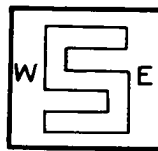

Figure 9: Photo of broken surface of 12052,1 showing pyroxene crystals in vugs. NASA #S70-44847. Scale 1 cm.



THE CUTTING AND CHIPPING OF LUNAR ROCK 12052,1

DRAWING 1



THE CUTTING AND CHIPPING OF LUNAR ROCK 12052,11

DRAWING 2

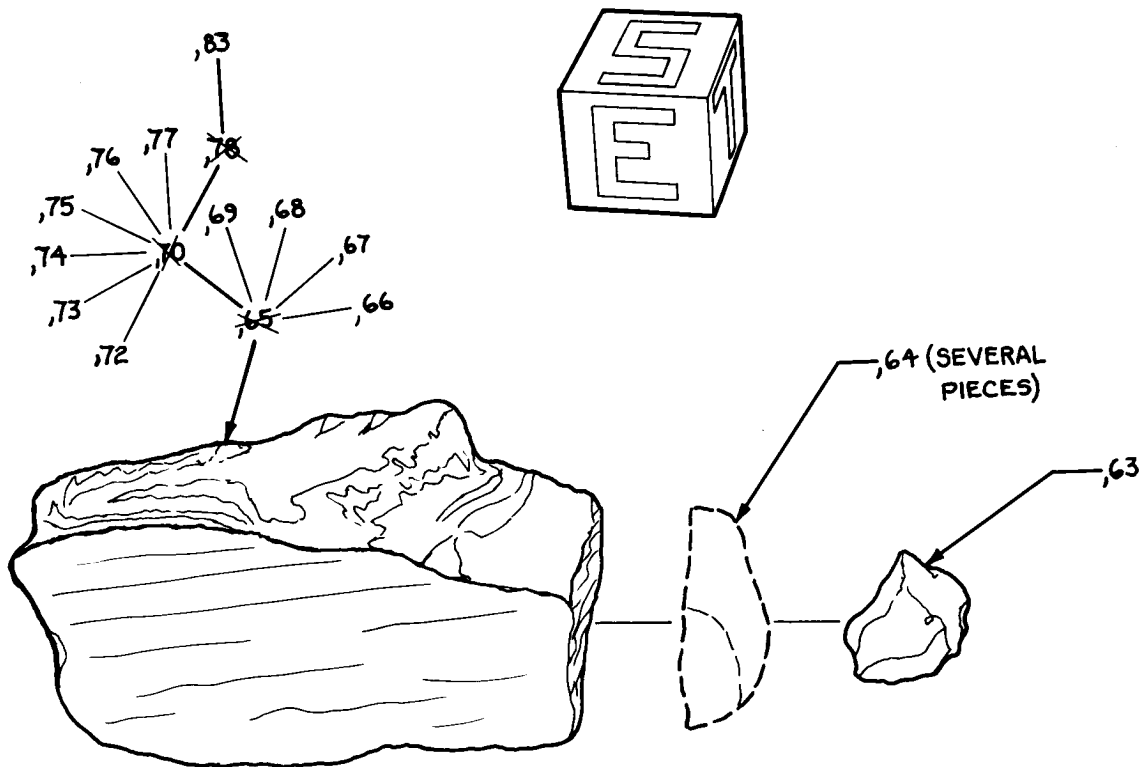
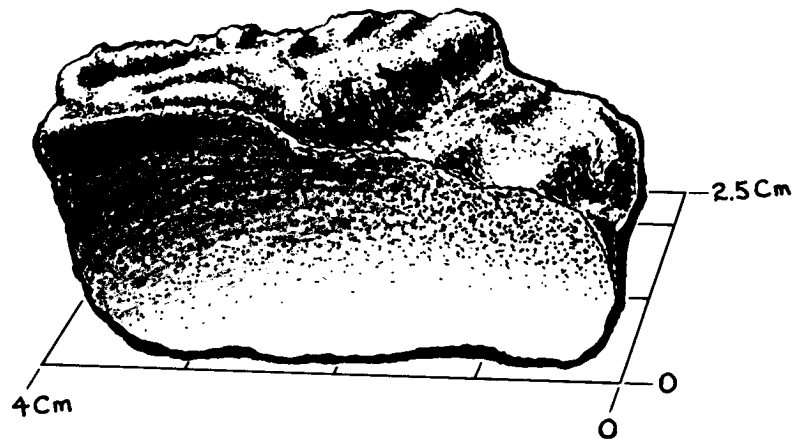

THE CUTTING AND CHIPPING OF LUNAR ROCK 12052,12

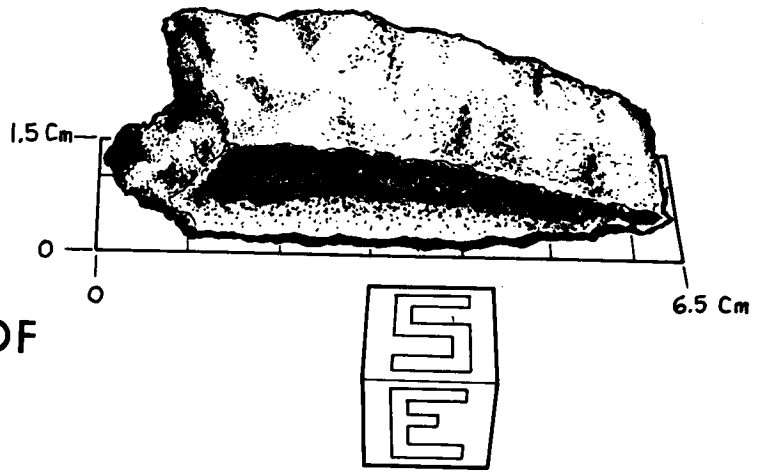

DRAWING 3

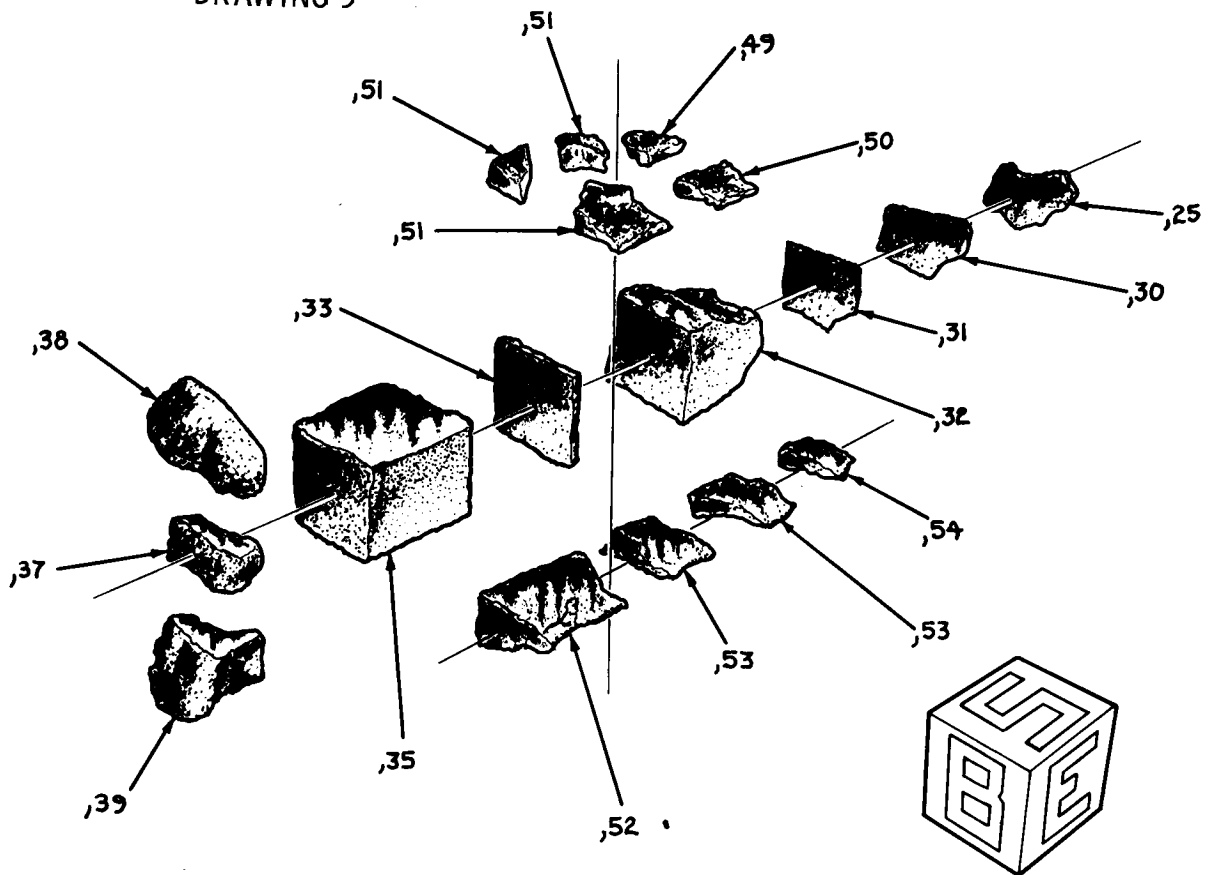

THE CUTTING AND CHIPPING OF LUNAR ROCK 12052,13

DRAWING 4

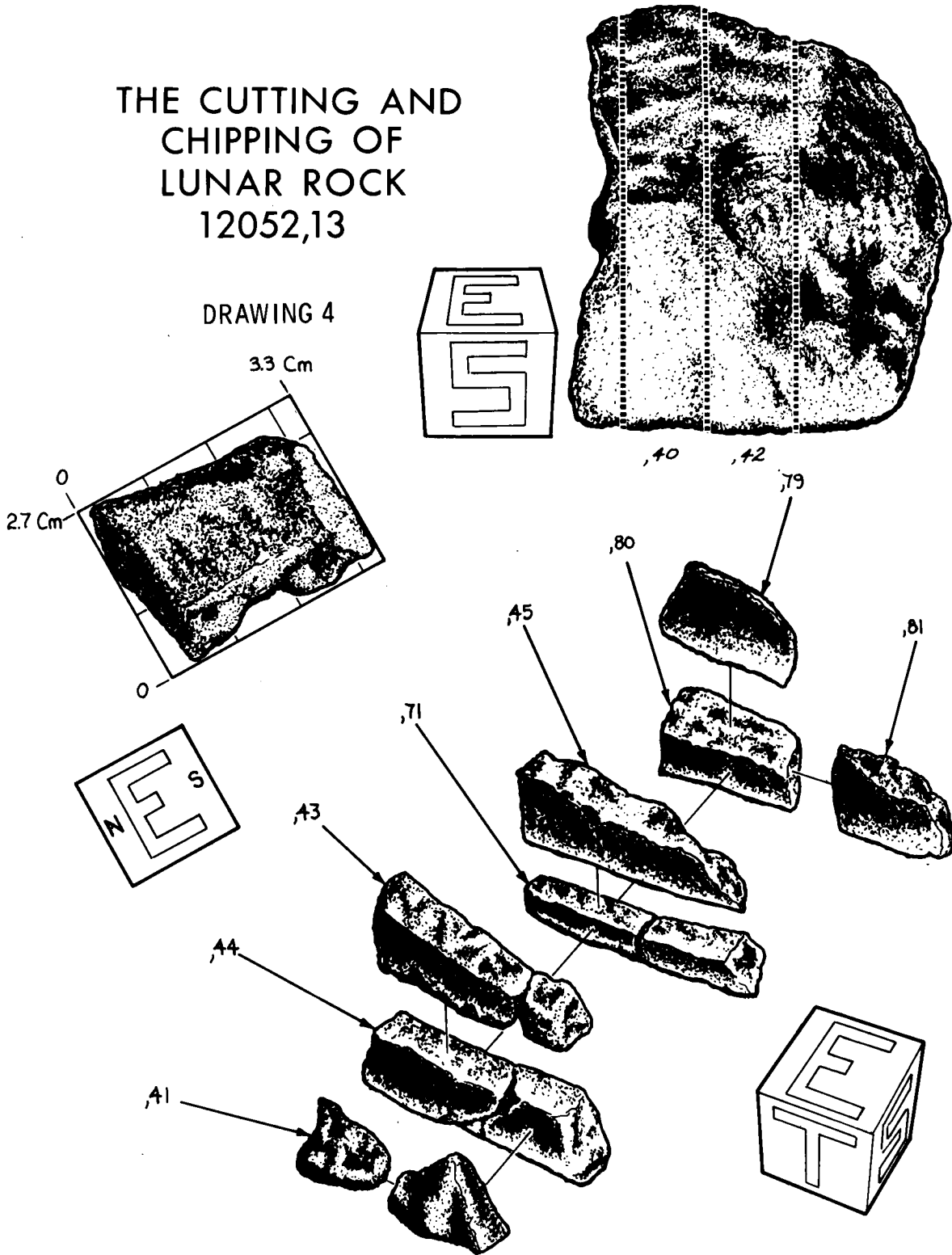

THE CUTTING AND CHIPPING OF LUNAR ROCK 12052,14

REVISION 1 11-4-70

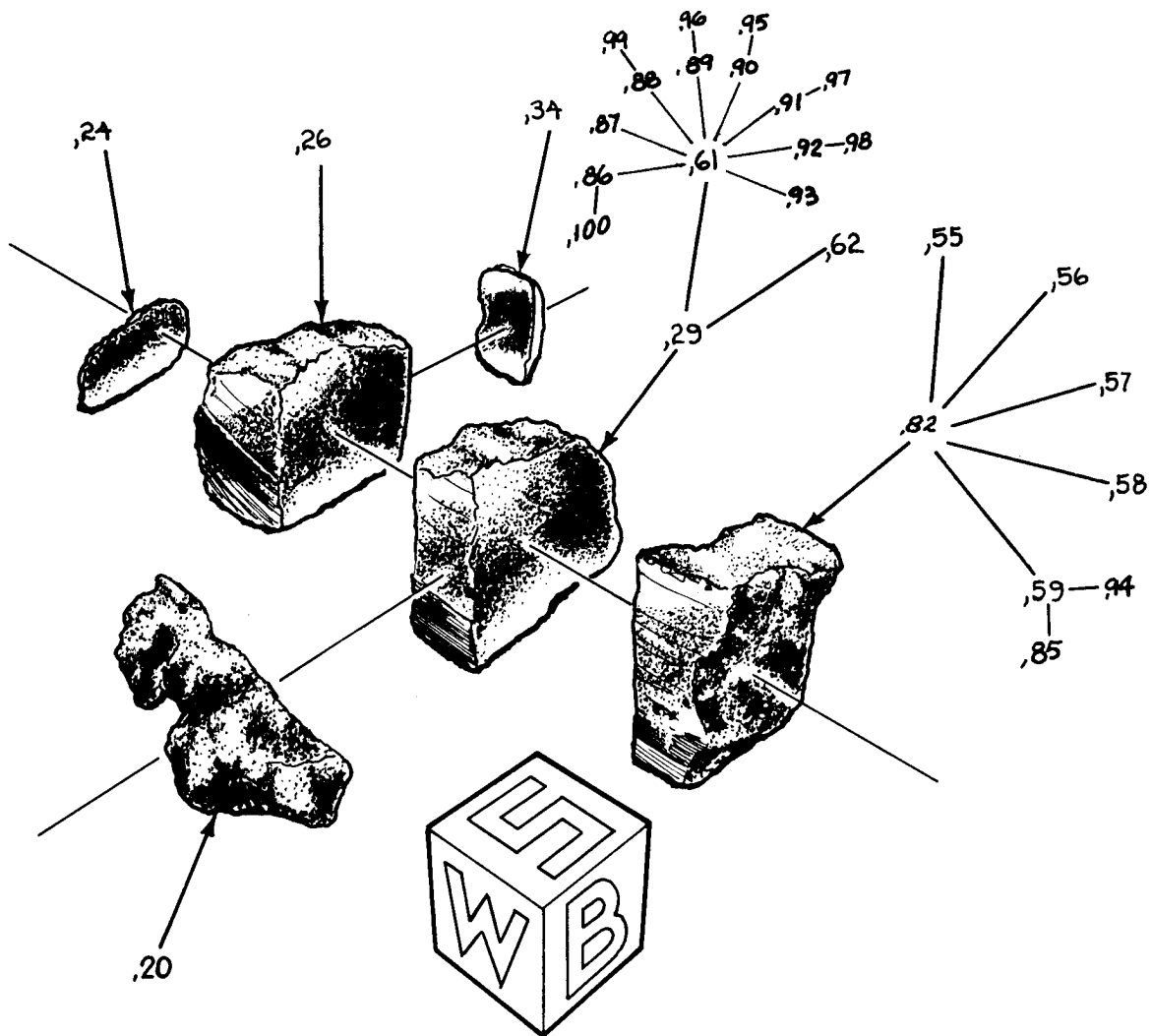
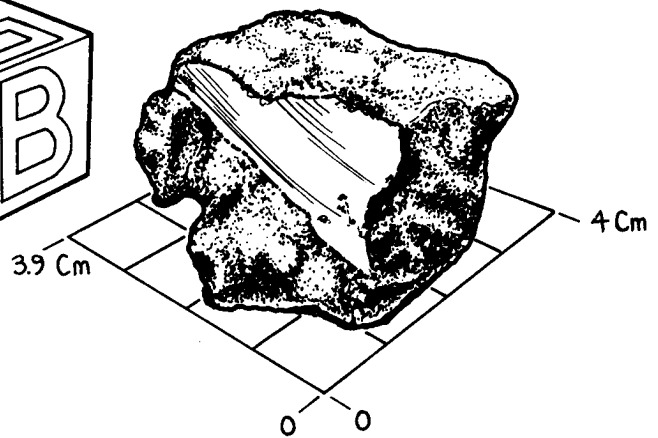
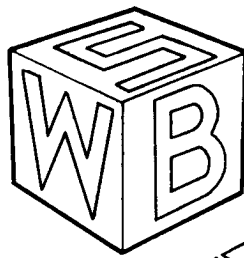

References for 12052

- Baldrige W.S., Beaty D.W., Hill S.M.R. and Albee A.L. (1979) The petrology of the Apollo 12 pigeonite basalt suite. *Proc. 10th Lunar Planet. Sci. Conf.* 141-179.
- Bence A.E., Papike J.J. and Prewitt C.T. (1970) Apollo 12 clinopyroxene chemical trends. *Earth Planet. Sci. Lett.* **8**, 393-399.
- Bence A.E., Papike J.J. and Lindsley D.H. (1971) Crystallization histories of clinopyroxenes in two porphyritic rocks from Oceanus Procellarum. *Proc. 2nd Lunar Sci. Conf.* 559-574.
- Bence A.E. and Papike J.J. (1972) Pyroxenes as recorders of lunar basalt petrogenesis: Chemical trends due to crystal-liquid interaction. *Proc. 3rd Lunar Sci. Conf.* 431-469.
- Bence A.E. and Autier B. (1972) Secondary ion analysis of pyroxenes from two porphyritic lunar basalts. In **The Apollo 15 Lunar Samples**, 191-194. The Lunar Science Institute, Houston.
- Bogard D.D., Funkhouser J.G., Schaeffer O.A. and Zahringer J. (1971) Noble gas abundances in lunar material-cosmic ray spallation products and radiation ages from the Sea of Tranquility and the Ocean of Storms. *J. Geophys. Res.* **76**, 2757-2779.
- Compston W., Berry H., Vernon M.J., Chappell B.W. and Kay M.J. (1971) Rubidium-strontium chronology and chemistry of lunar material from the Ocean of Storms. *Proc. 2nd Lunar Sci. Conf.* 1471-1485.
- Gibb F.G.F., Stumpfl E.F. and Zussman J. (1970) Opaque minerals in an Apollo 12 rock. *Earth Planet. Sci. Lett.* **9**, 217-224.
- Gibb F.G.F. and Zussman J. (1971) Zoned olivine in four Apollo 12 samples. *Earth Planet. Sci. Lett.* **11**, 161-167.
- Hintenberger H., Weber H.W. and Takaoka N. (1971) Concentrations and isotopic abundances of the rare gases in lunar matter. *Proc. 2nd Lunar Sci. Conf.* 1607-1625.
- Kushiro I., Nakamura Y., Kitayama K. and Akimoto S-I. (1971) Petrology of some Apollo 12 crystalline rocks. *Proc. 2nd Lunar Sci. Conf.* 481-495.
- Marti K. and Lugmair G.W. (1971) Kr⁸¹-Kr and Kr-Ar⁴⁰ ages, cosmic-ray spallation products and neutron effects in lunar samples from Oceanus Procellarum. *Proc. 2nd Lunar Sci. Conf.* 1591-1605.
- Maxwell J.A. and Wiik H.B. (1971) Chemical composition of Apollo 12 lunar samples 12004, 12033, 12051, 12052 and 12065. *Earth Planet. Sci. Lett.* **10**, 285-288.
- Murthy V.R., Evensen N.M., Jahn B.-M. and Coscio M.R. (1971) Rb-Sr ages and elemental abundances of K, Rb, Sr and Ba in samples from the Ocean of Storms. *Geochim. Cosmochim. Acta* **35**, 1139-1153.
- Neal C.R., Hacker M.D., Snyder G.A., Taylor L.A., Liu Y.-G. and Schmitt R.A. (1994a) Basalt generation at the Apollo 12 site, Part 1: New data, classification and re-evaluation. *Meteoritics* **29**, 334-348.
- Neal C.R., Hacker M.D., Snyder G.A., Taylor L.A., Liu Y.-G. and Schmitt R.A. (1994b) Basalt generation at the Apollo 12 site, Part 2: Source heterogeneity, multiple melts and crustal contamination. *Meteoritics* **29**, 349-361.
- Nyquist L.E., Bansal B.M., Wooden J. and Wiesmann H. (1977) Sr-isotopic constraints on the petrogenesis of Apollo 12 mare basalts. *Proc. 8th Lunar Sci. Conf.* 1383-1415.
- O'Kelley G.D., Eldridge J.S., Schonfeld E. and Bell P.R. (1971a) Abundances of the primordial radionuclides K, Th, and U in Apollo 12 lunar samples by nondestructive gamma-ray spectroscopy: implications for the origin of lunar soils. *Proc. Second Lunar Sci. Conf.* 1159-1168.
- O'Kelley G.D., Eldridge J.S., Schonfeld E. and Bell P.R. (1971b) Cosmogenic radionuclide concentrations and exposure ages of lunar samples from Apollo 12. *Proc. Second Lunar Sci. Conf.* 1747-1755.
- Papike J.J., Bence A.E., Brown G.E., Prewitt C.T. and Wu C.H. (1971) Apollo 12 clinopyroxenes: Exsolution and epitaxy. *Earth Planet. Sci. Lett.* **10**, 307-315.
- Papike J.J., Hodges F.N., Bence A.E., Cameron M. and Rhodes J.M. (1976) Mare basalts: Crystal chemistry, mineralogy and petrology. *Rev. Geophys. Space Phys.* **14**, 475-540.
- Schnetzler C.C. and Philpotts J.A. (1971) Alkali, alkaline earth, and rare earth element concentrations in some Apollo 12 soils, rocks, and separated phases. *Proc. 2nd Lunar Sci. Conf.* 1101-1122.
- Takeda H. (1972) Structural studies of rim augite and core pigeonite from lunar rock 12052. *Earth Planet. Sci. Lett.* **15**, 65-71.
- Tatsumoto M., Knight R.J. and Doe B.R. (1971) U-Th-Pb systematic of Apollo lunar samples. *Proc. 2nd Lunar Sci. Conf.* 1521-1546.

Taylor S.R., Rudowski R., Muir P., Graham A. and Kaye M. (1971) Trace element chemistry of lunar samples from the Ocean of Storms. *Proc. 2nd Lunar Sci. Conf.* 1083-1099.

Wänke H., Wlotzka F., M. and Rieder R. (1971) Apollo 12 samples: Chemical composition and its relation to sample locations and exposure ages, the two component origin of the various soil samples and studies on lunar metallic particles. *Proc. 2nd Lunar Sci. Conf.* 1187-1208.