



NATIONAL AERONAUTICS AND SPACE ADMINISTRATION

APOLLO 16 COARSE FINES (4-10 MM):

SAMPLE CLASSIFICATION, DESCRIPTION AND INVENTORY

Ursula B. Marvin
Smithsonian Institution
Astrophysical Observatory
Cambridge, Massachusetts

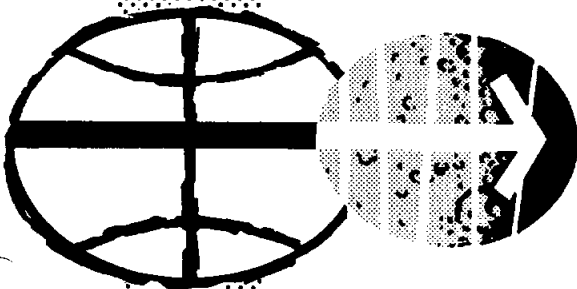

MANNED SPACECRAFT CENTER
HOUSTON, TEXAS

October 1972

TABLE OF CONTENTS

<u>SECTION</u>	<u>Page</u>
INTRODUCTION	1
SAMPLE NUMBERS AND LOCATIONS.	2
SAMPLE PROCESSING.	5
SAMPLE CLASSIFICATION	6
CLASSIFICATION OUTLINE	11
SAMPLE DESCRIPTIONS.	13
ACKNOWLEDGEMENTS AND CAVEAT.	143
REFERENCES	143
 <u>TABLES</u>	
1 Inventory of Apollo 16 4-10 mm fines	137
 <u>FIGURES</u>	
1 Apollo 16 Landing Site	3
2 Apollo 16 Station Locations.	4

INTRODUCTION

This catalogue summarizes the range and proportions of rock types observed during a binocular microscope examination of the Apollo 16 4-10 mm coarse fines. As the examination was made through the window of the nitrogen lines at the Manned Spacecraft Center, without the aid of thin sections or analyses of any kind, all classifications, particularly those of crystalline rocks, are strictly tentative. The purpose of the report is to provide lunar investigators with information on which they may select and seek allocation of particles from this size range for detailed study.

SAMPLE NUMBERS AND LOCATIONS

Soil samples were taken at the 10 stations along the EVA traverses sketched in Figures 1 and 2. The specific sampling sites of the soil samples that yielded the 4-10 mm fines described in this report are shown in the planimetric diagrams accompanying the sample descriptions. Each sample was assigned a number beginning with 6 (which identifies it with Apollo 16) and ending in 4 (which refers to the 4-10 mm size range). In most cases the second digit of the sample number refers to the sampling site; exceptions occur for stations 3 and 7 which were skipped on the EVAs. Digits 3 and 7 therefore refer to stations 13 and 11 respectively:

Sample No.	Station
60004	10
61004	1
62004	2
63004	13
64004	4
65004	5
66004	6
67004	11
68004	8
69004	9

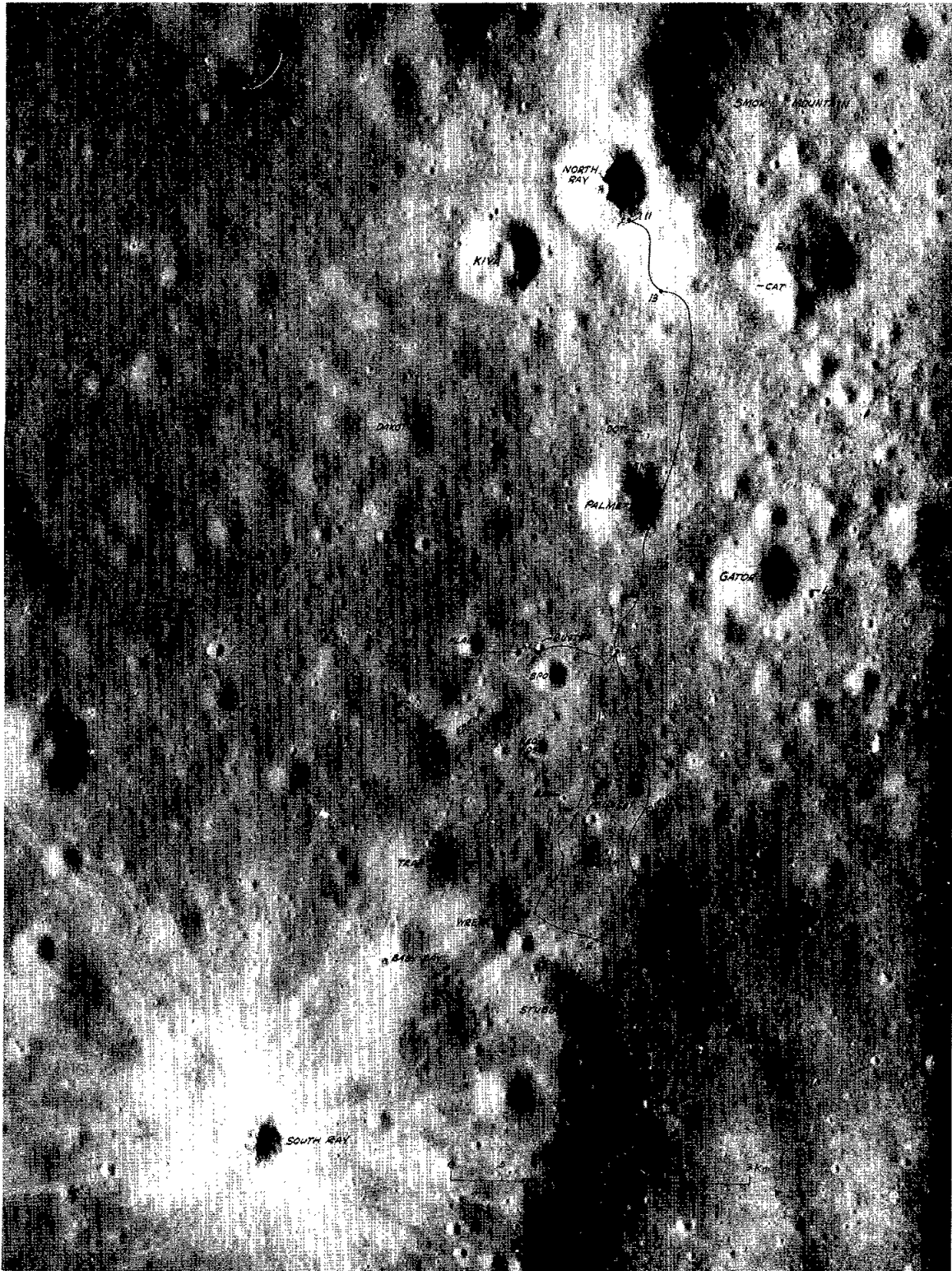
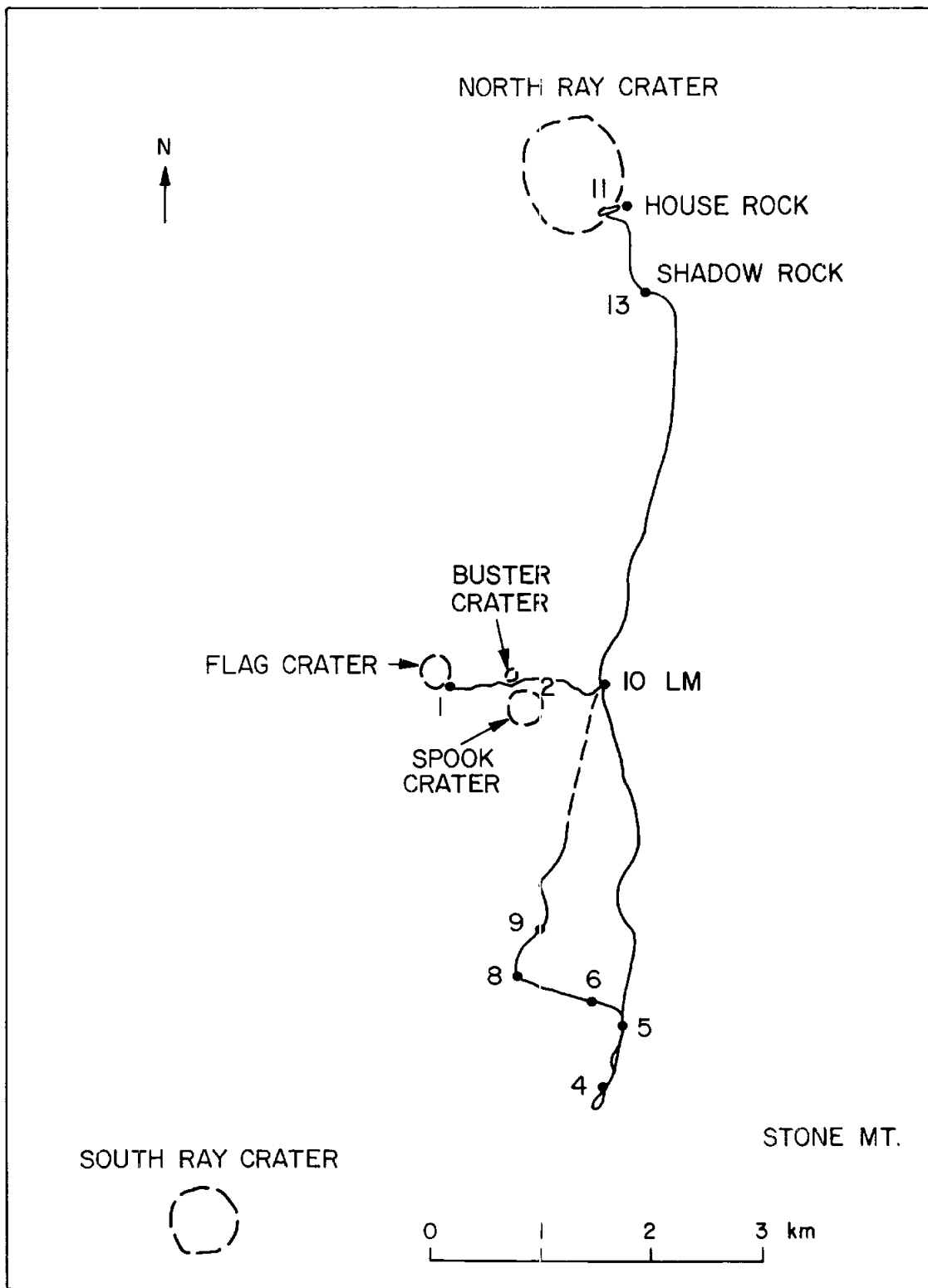

Figure 1. The Apollo 16 Landing site. Photograph with tracing of the EVA traverses and sample collection stations from U.S. Geological Survey Interagency Report.



APOLLO 16 STATION LOCATIONS

Figure 2

SAMPLE PROCESSING

The soil samples were returned from the moon in documented bags that were opened in the nitrogen lines at the Manned Spacecraft Center. One-quarter to one-third of each sample was weighed and stored as a reserve for future use. The remaining sample was sieved and all particles coarser than 1 cm were described as individual rocks (Apollo 16 Lunar Sample Information Catalogue). The 4-10 mm range is the coarsest of the soil fractions.

For the purpose of macroscopic examination, most of the particles in the 4-10 mm size range were dusted off individually by holding them with forceps in a jet of N₂. After dusting, the particles were separated into categories on the basis of their lithologic character as viewed through a binocular microscope. A few samples, however, had been stored in a section of the nitrogen lines remote from dusting equipment; these were classified without dusting. These samples are labeled "undusted" as their classification is less reliable than that of the cleaned particles.

After separation into categories each group of particles was described and photographed. All of the sample descriptions and a representative selection of photographs are included in this catalogue.

SAMPLE CLASSIFICATION

The Descartes region is the first remote highland site visited on the Apollo missions and this fact is reflected in the absence of mare basalts from the hand specimens and the coarse fines. Breccias of various types are the predominant rock type, but crystalline rocks, most of which are fine-grained and probably recrystallized, are also abundant.

On preliminary examination, the Apollo 16 hand specimens were separated into the following four categories: (see Apollo 16 Lunar Sample Information Catalogue) 1. Clastic matrix breccias that are white to very light gray and moderately friable with fine-grained matrix material of less than a few tenths of a millimeter. 2. Crushed anorthosites which are white and highly brecciated. 3. Coherent crystallines in a variety of homogeneous types with plagioclase ranging upward from 70%. 4. Gray and white breccias, each of which consists partly of gray clasts in a white matrix and partly of white clasts in a gray matrix.

In the 4-10 mm fines, all distinction is lost between the breccias of categories 1 and 4. Gray and white breccias are abundant, but no particles are large enough to exhibit interchangeable matrix-clast relationships. The crushed anorthosites of category 2 are present but anorthosites also occur in several other textures and degrees of crystallinity. Rocks of category 3 are abundant in the 4-10 mm fines, where many of them appear to be recrystallized glass. Several additional rock types are also present in the 4-10 mm fines, including soil breccias, glasses, various polymineralic crystallines, and one unique metal particle.

The following rock types were established among the 4-10 mm particles:

1. Soil microbreccias and glass-welded aggregates

This category includes brown to gray polymict microbreccias that are darker in color than the common plagioclase-rich rocks of the lunar terrae. Some of the microbreccias are very friable and consist of rock, mineral, and glass clasts in a matrix of very fine-grained soil; others are coherent particles, lightly to strongly annealed, with relict clasts in a dark colored recrystallized matrix. Many particles, whether friable or annealed, are partially coated with brown cindery glass. In some cases, two or more particles of microbreccia are welded together in a delicate aggregate by crusts and filaments of cindery glass. The dark friable breccias, glass-welded aggregates, and annealed breccias are all assumed to be products formed and reprocessed in the lunar regolith. For purposes of this catalogue they are grouped in a single category as class 1a, 1b, and 1c respectively.

2. Glass

Glass occurs as spherules and other free forms, as angular shards, and as irregular vesicular masses. Some glassy particles are vitreous but the majority are devitrified to aphanitic materials that are translucent to opaque. Many are coated with fine dust and soil. The commonest colors among the Apollo 16 glasses are dark gray and brown, but dark green, dark yellow, and colorless to milky-white glasses are also present. Conspicuously absent are the light apple-green glasses that were a striking feature of the Apollo 15 soils.

3. Gray and white breccias

a. Friable. Clastic particles with gray and white components in various proportions are abundant in these samples. In general, the white material is the more friable and tends to crumble away leaving coherent nodules, clasts, and webby veinlets of gray fine-grained to aphanitic material. The white phase is plagioclase crushed or shocked to very fine grain size. The gray material is also plagioclase-rich and may be partially glassy, but its actual composition and texture await thin section examinations.

b. Coherent. These are mottled gray and white rocks that appear to be annealed microbreccias. Such rocks may be either cataclastically deformed and recrystallized bed-rock or annealed aggregates formed in the regolith over the terrae.

4. Fine-grained crystallines

Fine-grained to aphanitic particles that are uniformly gray or light brown are abundant in the 4-10 mm fines. These particles are designated as fine-grained crystallines because they are essentially nondescript. Many of them are angular and blocky, others have rounded surfaces and appear nodular; still others are markedly rough and pitted with small vesicles. All particles in this category are coherent to tough and tend to break with smooth fracture surfaces. Many are coated with white dust and are, in all probability, disaggregated inclusions from friable gray and white microbreccias. These particles could be subdivided on the basis of shape or shades of color but in general this was not done because their broad similarities seemed to outweigh their differences. However, the fine-grained crystallines of category 4 grade toward several other categories including glass-rich particles (2), annealed gray and white microbreccias (3b), crystalline anorthosites (5c), and gray crystallines (6a).

5. Anorthosites

Rocks consisting mainly of plagioclase feldspar occur as (a) clastic microbreccias, (b) chalky white particles with or without sparse black angular inclusions, (c) fine-grained essentially monomineralic crystallines, (d) gabbroic anorthosites. The clastic breccias consist of angular fragments that are white, colorless, or light gray in a very fine-grained white matrix. They are clearly aggregates in which both the clasts and the matrix materials were ultimately derived from the same or similar anorthositic source rocks. Contrasting with the clastic breccias are particles consisting mainly of chalky white material some of which contain black aphanitic inclusions that are often rhombic in cross section. This type of particle is not a polymict breccia but appears to be an anorthositic rock in which the feldspar

and other constituents, possibly including single grains of olivine and pyroxene, have been shocked to a microcrystalline or glassy state. An understanding of these particles will require extensive studies of thin sections. Crystalline anorthosites occur as white equigranular rocks resembling fine-grained lumps of sugar, and also as porous intergrowths of euhedral and subhedral feldspar laths. In general the only visible components other than feldspar in the crystalline anorthosites are sparse grains of metal or sulfide. Gabbroic anorthosites include rocks consisting of plagioclase plus up to 35% of yellow or light brown mafic silicates. Most of the particles classified as anorthosites are white or nearly white. Numerous gray breccias or crystallines of categories 3, 4, or 6 may also prove to be anorthositic when studied in thin sections.

6. Gray crystallines

Crystallines of a distinctly gray color suggestive of the presence of fine-grained opaques along with feldspar and mafic silicates occur as (a) sugary equigranular materials and (b) "salt-and-pepper" rocks with a "granitic" to "gneissic" appearance. The equigranular crystallines vary from light to rather dark gray and resemble the norites of earlier Apollo samples. The "salt-and-pepper" rocks are uncommon and of uncertain character.

7. Exceptional particles

This category embraces any particle with an unusual composition or texture. It includes particles with interesting drusy vugs and rocks such as a gabbroic microporphyry, a possible variolitic basalt, and a unique aggregate of metallic globules.

Descriptive Terms

In the sample descriptions the degrees of coherence are indicated in the following terms:

Very friable: crumbles on gentle handling

Friable: crumbles on moderate pressure

Coherent: breaks along grain boundaries when struck with moderate force

Tough: breaks across grain boundaries; requires great force

Brittle: applies to glasses

Most descriptions refer to several particles rather than a single one. Thus a phrase such as "friable to coherent" means that some grains are friable, others are coherent. Competent grains that are very fine-grained to aphanitic are generally described as tough although macroscopically it is difficult to decide whether they break along or across grain boundaries.

When fractures are visible in coherent or tough materials they are described as non-penetrative if they occur on only one side of a particle; as penetrative if they are seen on both sides.

Classification Outline

1. Microbreccias (dark-colored regolith products)
 - a. Friable
 - b. Glass-welded aggregates
 - c. Annealed
2. Glass
3. Gray and white microbreccias
 - a. Friable
 - b. Coherent
4. Fine-grained crystallines (nondescript)
5. Anorthosites
 - a. Clastic microbreccias
 - b. Chalky particles with or without angular black
inclusions
 - c. Crystallines (equigranular or felty)
 - d. Gabbroic anorthosites
6. Gray crystallines
 - a. Sugary, equigranular (norites?)
 - b. "Salt-and-pepper" rocks
7. Exceptional particles

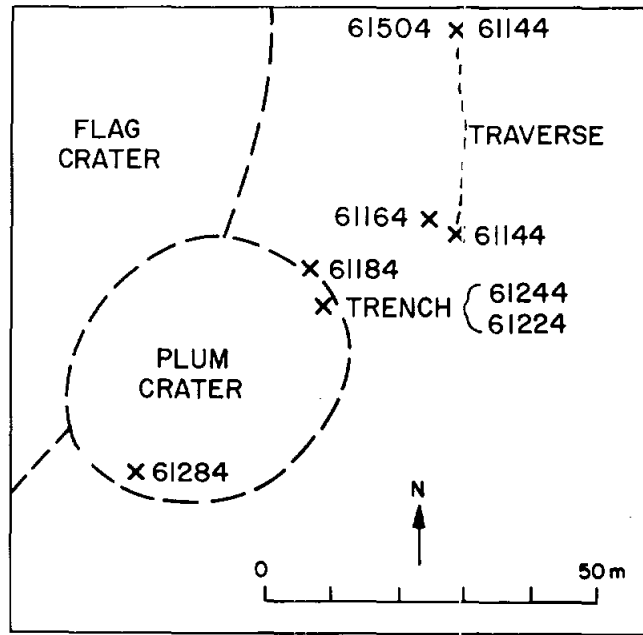

STATION 1

Station 1 is located in gently undulating terrain near the east rim of Flag Crater, a feature 200 m in diameter with an original depth calculated at about 40 m. Flag Crater is believed to have penetrated the regolith and excavated the upper layers of the underlying Cayley Formation. Soil sample 61144 was collected on a N-S traverse about 30 meters east of the crater rim. Samples 61504 and 61164 were taken near the ends of the traverse. Four samples were collected from the rim of Plum Crater, a small feature 40 m in diameter sculptured in the SE rim of Flag Crater. Sample 61184 is a surface sample of rim material; sample 61244 is from gray surface soil in the wall of a trench, and sample 61224 is from a white layer at a shallow depth in the trench. Sample 61284 is from a fillet-- a deposit of soil banked smoothly against a boulder-- in the rim of Plum Crater.

SAMPLE 61144,1

Rock Type: Glass-welded aggregates and microbreccias (1a,1b)
Coherence (intergranular): Friable to lightly coherent
Shape: Individual pieces, subangular
Surface: Breccia surfaces smooth; glass cindery
Color: Matrixes gray; angular inclusions dark and light
Special Features: Thick coatings of brown vesicular glass
No. of Particles: 6 / Weight: 0.78g

Remarks: Lithic fragments present in breccias

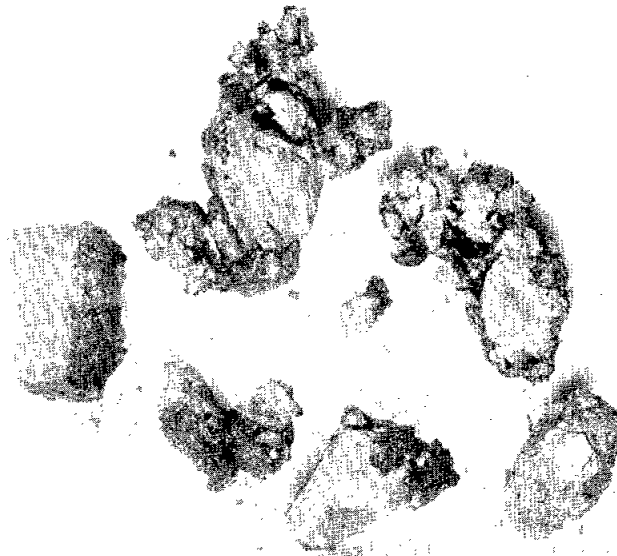

SAMPLE 61144,2

Rock Type: Gabbroic anorthosite (5d)
Coherence (intergranular): Very friable; penetrative fractures
Shape: Subrounded from the shedding of grains
Surface: Rough, granular
Color: Yellowish white
Special Features: A few small interstitial cavities
No. of Particles: 1 / Weight: 0.52g

Remarks: The particle is lustrous with feldspar cleavage faces. It consists of about 80% plagioclase in white laths up to 2 mm long and 20% mafic silicates in yellow interstitial grains.

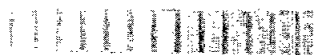
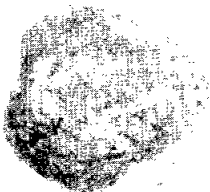

SAMPLE 61144,3

Rock Type: Variolitic basalt (?) (7)
Coherence (intergranular): Coherent
Shape: Subangular; somewhat tabular
Surface: Smooth upper surface; chipped sides
Color: Gray; aphanitic
Special Features: Numerous zap pits on upper surface
No. of Particles: 1 / Weight: 0.29 g

Remarks: This particle is uniformly gray and aphanitic except for skeletal crystals 2 to 5 mm long that are visible on one surface. On this basis the particle is classed, tentatively, as a variolitic basalt.

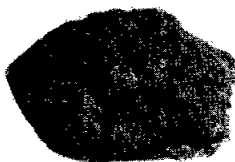

SAMPLE 61144,4

Rock Type: Fine-grained crystallines (4)
Coherence (intergranular): Coherent to tough
Shape: Angular to irregular
Surface: Rough, partially coated with soil
Color: Gray to brown
Special Features: Numerous small cavities and rounded vesicles
No. of Particles: 14/ Weight: 3.49g

Remarks: Some of these particles appear to be devitrified glass; others may be annealed microbreccias.

SAMPLE 61504,1

Rock Type: Microbreccias and a glass-welded aggregate (1a,1b,1c)
Coherence (intergranular): Very friable to coherent
Shape: Angular and blocky to rounded
Surface: Rough and partially coated with brown vesicular glass
Color: Matrixes light brown to gray, and black
Special Features: None
No. of Particles: 7 / Weight: 1.69g

Remarks: These particles vary from friable soil breccias to 2 (right) with black annealed matrixes.

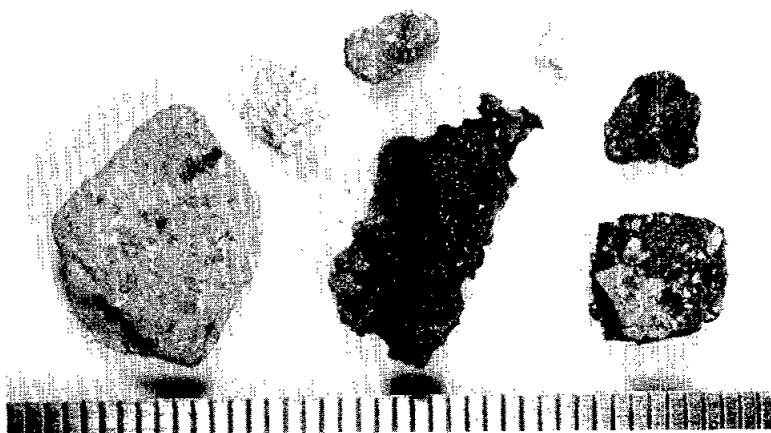

SAMPLE 61504,2

Rock Type: Glass-rich particles (2)
Coherence (intergranular): Brittle; conchoidal fracture
Shape: Irregular
Surface: Rough, vesicular; partially coated with soil
Color: Gray; aphanitic
Special Features: None
No. of Particles: 6 / Weight: 2.43g

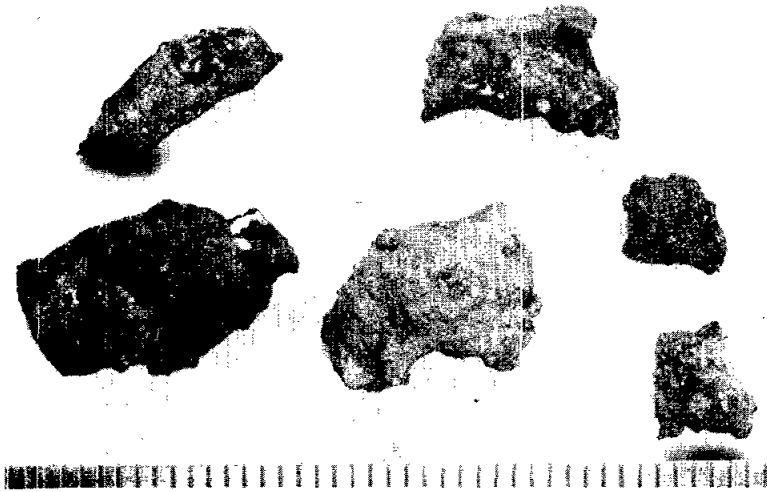

SAMPLE 61504,3

Rock Type: Fine-grained crystallines (4)
Coherence (intergranular): Coherent, tough; some non-penetrative fractures
Shape: Angular
Surface: Rough; some particles vesicular
Color: Various shades of gray and brown
Special Features: Tiny vesicles and zap pits common
No. of Particles: 25/ Weight: 5.93g

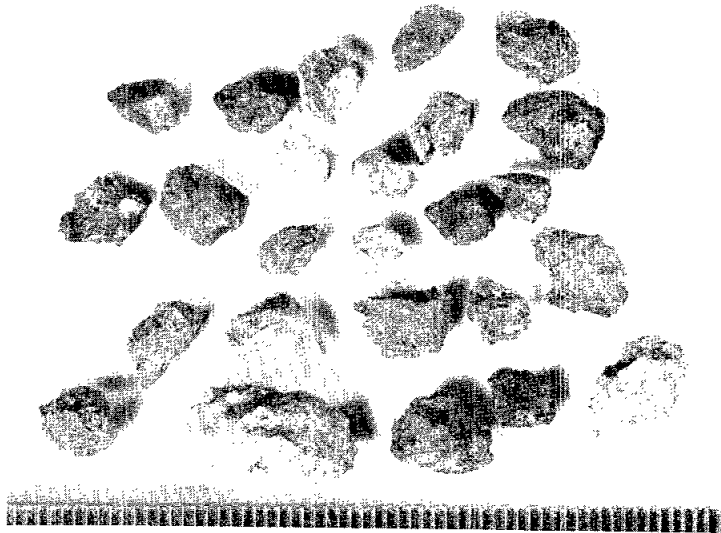

SAMPLE 61504,4

Rock Type: Anorthosites (5c)
Coherence (intergranular): Tough; with minor small fractures
Shape: Angular to rounded
Surface: Fine-grained, equigranular
Color: White to light gray
Special Features: None
No. of Particles: 5 / Weight: 1.01g



SAMPLE 61504,5

Rock Type: Exceptional particles (7)
No. of Particles: 3 / Weight: 1.06g

Remarks: One particle (right) is a soil microbreccia with a conspicuous clast of light green glassy material that is unusual in the Apollo 16 samples. The two larger particles are devitrified glasses having small vugs some of which are lined with colorless crystals; others carry aggregates of metal or troilite spherules.



SAMPLE 61164,1

Rock Type: Microbreccia and cindery glass (1a, 2)
Coherence (intergranular): Friable to coherent
Shape: Irregular
Surface: Lumpy
Color: Breccia matrix, light gray; glass brownish
Special Features: None
No. of Particles: 2 / Weight: 0.25g

Remarks: One particle (left) is a soil breccia coated with brown vesicular glass; the other (right) is mainly glass coated with soil.

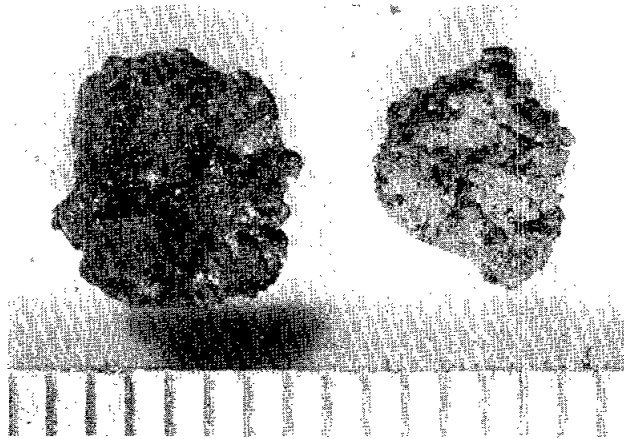

SAMPLE 61164,2

Rock Type: Glassy particles (2)
Coherence (intergranular): Brittle; conchoidal fracture
Shape: Angular
Surface: Rough and vesicular
Color: Dark gray
Special Features: Zap pits on some surfaces
No. of Particles: 2 / Weight: 0.94g

Remarks: Both particles are aphanitic at the surface but vitreous interiors are exposed in cavities.

61164,2

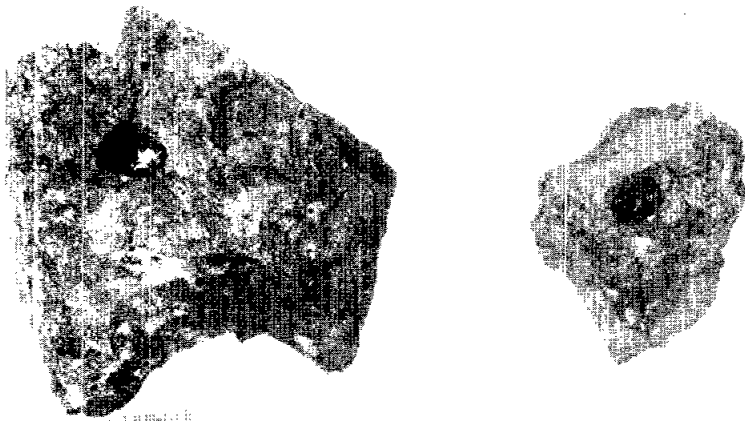

SAMPLE 61164,3

Rock Type: Gabbroic anorthosite (5d)
Coherence (intergranular): Friable
Shape: Subrounded
Surface: Interlocking mesh of plagioclase laths
Color: White with a small percentage of pale brown
Special Features: Irregular, interstitial cavities; soil on some
No. of Particles: 1 / Weight: 0.12g surfaces

Remarks: The particle consists of plagioclase (about 95%)
in subhedral crystals, and pale brown mafic
silicates (about 5%) plus sparse metal grains.



SAMPLE 61164,4

Rock Type: Fine-grained crystallines (4)
Coherence (intergranular): Coherent to tough
Shape: Angular to rounded (nodular)
Surface: Smooth to granular; partly dust-coated
Color: Gray to nearly white
Special Features: A few small vesicles; zap pits on some surfaces
No. of Particles: 5 / Weight: 0.84g

Remarks: These particles range from gray to off-white; some of them are faintly mottled and appear to have white relict clasts in a gray groundmass. Tiny metallic globules are exposed on some of the fractured surfaces. This group of crystallines grades toward annealed gray microbreccias (3b) and also toward anorthosites (5c).

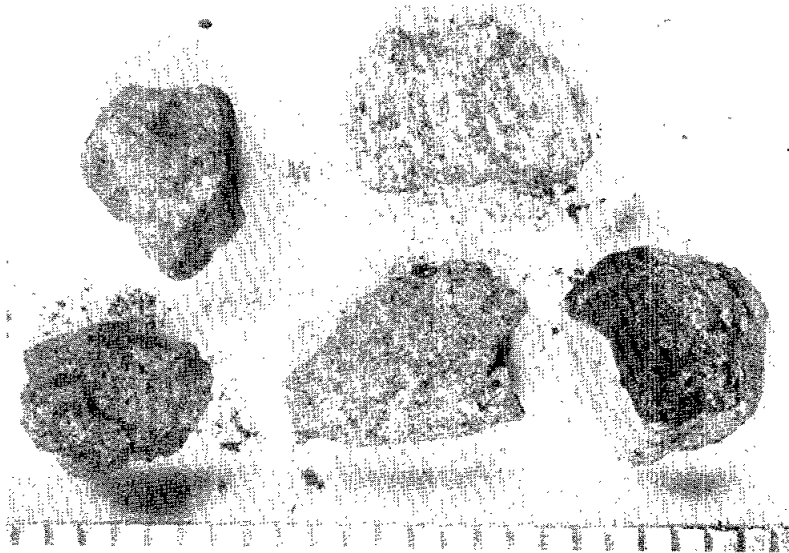

SAMPLE 61184,1

Rock Type: Microbreccias and a glass-welded aggregate (1a,1b)
Coherence (intergranular): Friable
Shape: Rounded
Surface: Rough, grainy
Color: Matrixes gray; clasts white and gray
Special Features: Partial coatings of brown cindery glass
No. of Particles: 3 / Weight: 0.70g

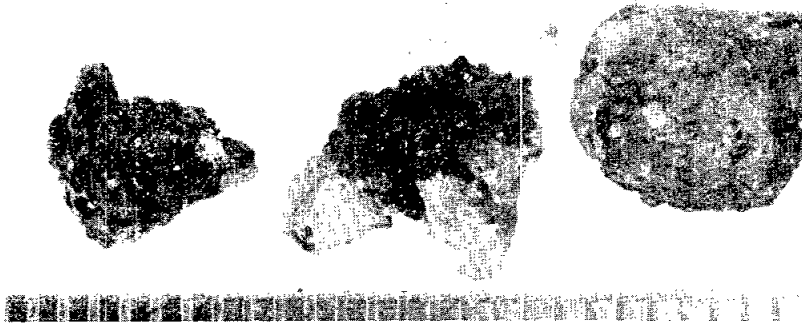

SAMPLE 61184,2

Rock Type: Glass-rich particles (2)
Coherence (intergranular): Tough; conchoidal fracture
Shape: Irregular
Surface: Vesicular
Color: Dark gray; aphanitic
Special Features: Clumps of metal globules in some vesicles
No. of Particles: 2 / Weight: 1.12g

Remarks: Four cavities in the larger particle contain aggregates of tiny metal spheres.



SAMPLE 61184,3

Rock Type: Anorthosite (5b)
Coherence (intergranular): Friable; with penetrative fractures
Shape: Subangular
Surface: Nearly smooth
Color: Chalky white with thin streaks and clasts of gray material
Special Features: None
No. of Particles: 1 / Weight: 0.27g



SAMPLE 61184,4

Rock Type: Anorthositic microbreccias (5a)
Coherence (intergranular): Friable; non-penetrative fractures
Shape: Rounded
Surface: Dusty and grainy
Color: Matrix white; clasts white and gray
Special Features: None
No. of Particles: 2 / Weight: 0.10g



SAMPLE 61184,5

Rock Type: Fine-grained crystallines (4)
Coherence (intergranular): Tough, competent
Shape: Angular
Surface: Smooth to sugary
Color: Gray to nearly white
Special Features: Small vesicles in some fragments
No. of Particles: 6 / Weight: 2.01g

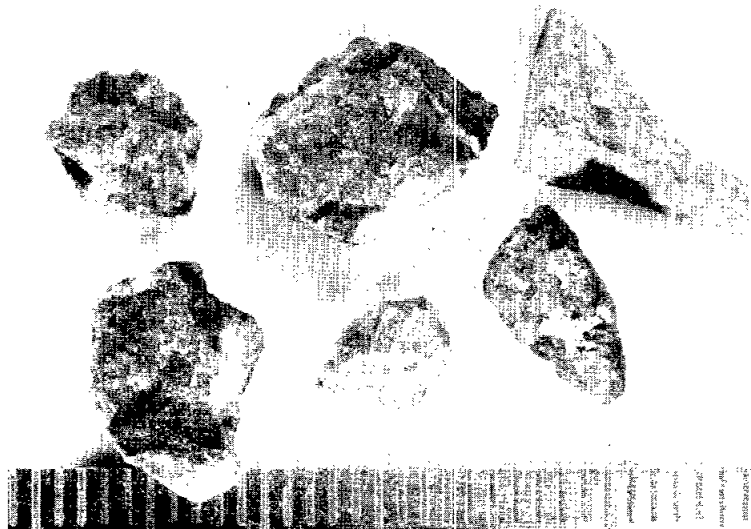

SAMPLE 61184,6

Rock Type: Anorthosite and gabbroic anorthosites (5c,5d)
Coherence (intergranular): Coherent
Shape: Subrounded to rounded
Surface: Rough, granular
Color: Yellowish white to gray
Special Features: See Remarks
No. of Particles: 3 / Weight: 1.86g

Remarks: Particle a is a medium-grained anorthosite with a small percentage of mafic silicates and no visible opaques.

Particle b consists partly of aphanitic gray vesicular material and partly of fine-grained crystalline anorthosite.

Particle c is yellowish and contains approximately 60% plagioclase, 40% mafic silicates, and a trace of opaques.

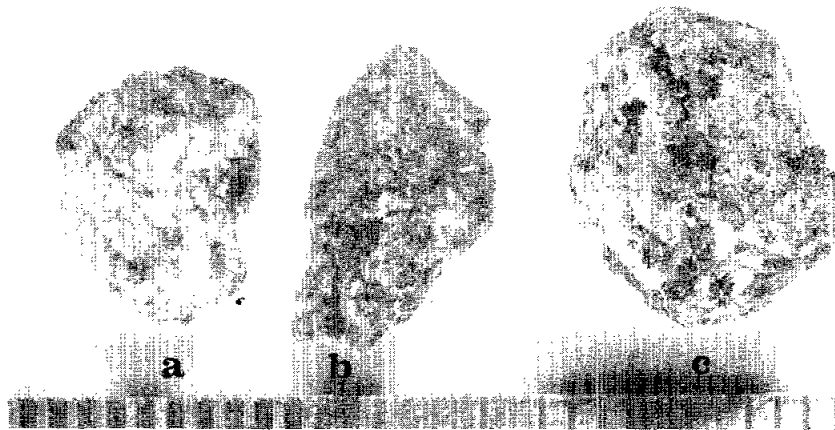

SAMPLE 61244,1

Rock Type: Microbreccias and glass-welded aggregates (1a,1b)
Coherence (intergranular): Very friable
Shape: Angular to irregular
Surface: Partially coated with brown cindery glass
Color: Matrixes light brown to gray; clasts various shapes and colors
Special Features: None
No. of Particles: 18/ Weight: 2.60g

SAMPLE 61244,2

Rock Type: Glass-rich particles (2)
Coherence (intergranular): Tough; fracture conchoidal
Shape: Irregular
Surface: Rough, vesicular; partly coated with fine soil
Color: Gray to brown, aphanitic
Special Features: Zap pits on some surfaces
No. of Particles: 6 / Weight: 0.67g

Remarks: These particles are probably recrystallized glasses and glass-rich breccias.

SAMPLE 61244,3

Rock Type: Fine-grained crystallines (4)
Coherence (intergranular): Coherent to tough
Shape: Angular, blocky
Surface: Smooth fractures; rough exteriors
Color: Gray to white
Special Features: Small vugs in some particles; zap pits rare
No. of Particles: 23/ Weight: 3.77g

Remarks: Many surfaces covered with fine soil

SAMPLE 61244,4

Rock Type: Anorthosites and gabbroic anorthosites (5c,5d)
Coherence (intergranular): Coherent
Shape: Angular
Surface: Rough, slabby
Color: Light gray to white
Special Features: None
No. of Particles: 7 / Weight: 3.10g

Remarks: Particle a is a fine-grained gray crystalline with small vugs and fractures lined with drusy feldspar crystals. One large feldspar crystal (5 mm) is embedded in the fine groundmass.

Particle b is a fine-grained gabbroic anorthosite; mainly white plagioclase with minor yellow and cinnamon mafics plus minute accessory opaques. It contains specks of shiny metal on fractured surfaces.

The sample also includes one 10 mm fragment of gabbroic anorthosite, consisting of plagioclase (60%) and yellow mafic silicates (40%), and four small, 4 mm fragments of white crystalline anorthosite.

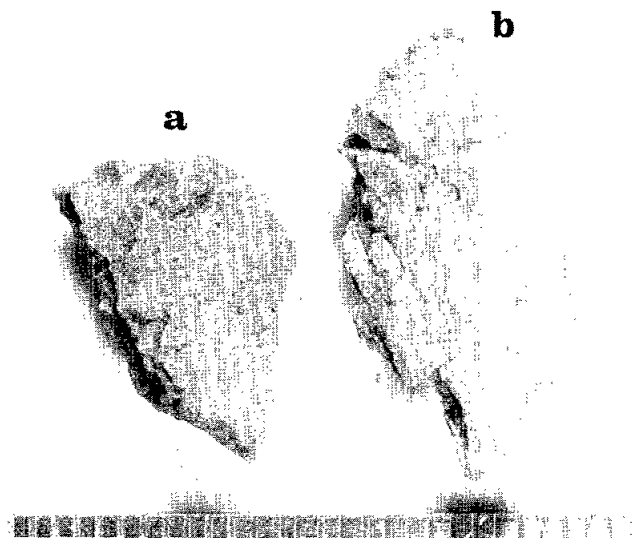

SAMPLE 61224,1

Rock Type: Microbreccias (1a)(3a)
Coherence (intergranular): Very friable and shedding
Shape: Rounded
Surface: Rough
Color: Matrixes, very light brown to light gray
Special Features: None
No. of Particles: 6 / Weight: 0.58g

Remarks: The darkest brown breccia contains gray and white angular clasts and rare spherules; the lighter breccias contain angular clasts that are colorless to white.

SAMPLE 61224,2

Rock Type: Glass (2)
Coherence (intergranular): Conchoidal fracture
Shape: Angular fragment
Surface: Vitreous
Color: Colorless to milky white
Special Features: No vesicles or zap pits
No. of Particles: 1 / Weight: 0.18g

Remarks: The fragment has vitreous luster but is translucent, almost milky and has tiny black and brown internal specks; some may be bubbles, others minute inclusions of dust. Light is reflected from internal curved fracture surfaces.

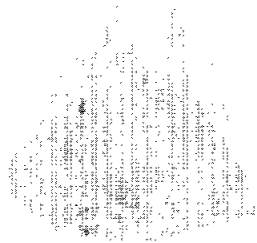

SAMPLE 61224,3

Rock Type: Fine-grained crystallines (4)
Coherence (intergranular): Tough
Shape: Angular, blocky
Surface: Mostly smooth; some coated with white dust
Color: Light to dark gray
Special Features: Small vesicles or irregular cavities in some
No. of Particles: 12/ Weight: 3.18g grains

Remarks: These particles are all aphanitic to fine-grained and may be recrystallized glass-rich rocks. Tiny metal grains are visible on some fractured surfaces.

SAMPLE 61224,4

Rock Type: Mottled gray crystallines (6a)
Coherence (intergranular): Tough
Shape: Angular
Surface: Smooth
Color: Light gray mottled with a darker component
Special Features: White dust on some surfaces
No. of Particles: 8 / Weight: 2.31g

Remarks: Macroscopically, these particles differ from the more abundant dense homogeneous crystallines of 61224,3 in having at least two components. They appear to consist mainly of fine-grained gray plagioclase with a small percentage of opaques including sparse metal grains. A mafic component, if present, is not distinguishable because of the small grain size.



SAMPLE 61224,5

Rock Type: Anorthosites and gabbroic anorthosites (5c,5d)
Coherence (intergranular): Coherent; some non-penetrative fractures
Shape: Angular
Surface: Smooth to sugary; partially coated with dust
Color: White to pale yellowish white
Special Features: Sparse zap pits
No. of Particles: 6 / Weight: 0.73g

Remarks: Two of these particles are sugary white, tough, and angular; the remaining four are fine-grained and consist mainly of plagioclase with a small percentage of yellow mafic silicates.



SAMPLE 61224,6

Rock Type: Gabbroic microporphyry (7)
Coherence (intergranular): Very friable; shedding crystals
Shape: Angular to subrounded
Surface: Granular
Color: Brown to greenish phenocrysts in white groundmass
Special Features: Thin shells of glass on some fractured surfaces
No. of Particles: 3 / Weight: 0.34g

Remarks: These particles are unique among the rock types in this size range. The three fragments have some rounded surfaces partially coated with white dust and may possibly be three pieces of one nodular mass. The groundmass is fine-grained white plagioclase (40%); the phenocrysts are pale brown to greenish euhedral and subhedral crystals of pyroxene (60%). No opaques are visible. Broken surfaces reveal some irregular interstitial cavities. Two fractured surfaces are partially coated with thin shells of smooth colorless and green glass apparently formed by melting of the underlying minerals.

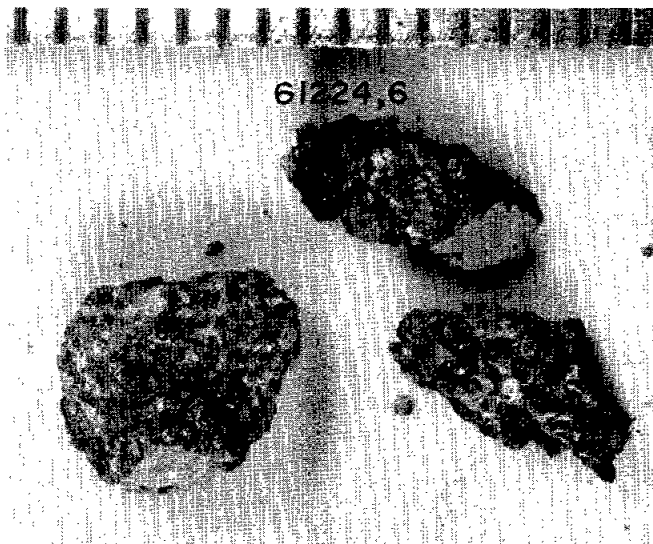

SAMPLE 61284,1

Rock Type: Microbreccias (1a)
Coherence (intergranular): Very friable
Shape: Subangular
Surface: Rough and partially coated with brown cindery glass
Color: Matrixes light brown; clasts predominantly white
Special Features: None
No. of Particles: 2 / Weight: 0.14g



SAMPLE 61284,2

Rock Type: Glassy particles (2)
Coherence (intergranular): Brittle; conchoidal fracture
Shape: One angular fragment; one rough spherule
Surface: Spherule coated with fine white dust
Color: Dark brown; aphanitic
Special Features: None
No. of Particles: 2 / Weight: 0.66g



SAMPLE 61284,3

Rock Type: Microbreccias (1a,1c)
Coherence (intergranular): Friable to coherent
Shape: Angular to subrounded
Surface: Rough, grainy
Color: Matrixes light brown to gray; clasts dark and light
Special Features: None
No. of Particles: 5 / Weight: 0.77g

SAMPLE 61284,4

Rock Type: Anorthosite (5b)
Coherence (intergranular): Friable
Shape: Angular
Surface: One surface coated with smooth black glass
Color: Chalky white
Special Features: None
No. of Particles: 1 / Weight: 0.04g



SAMPLE 61284,5

Rock Type: Crystallines (aphanitic to fine-grained) (4)
Coherence (intergranular): Tough, competent
Shape: Angular, blocky
Surface: Rough and irregular to smooth
Color: Various shades of gray, brown, and white
Special Features: Small vuggy cavities and vesicles
No. of Particles: 8 / Weight: 1.49g



SAMPLE 61284,6

Rock Type: Gabbroic anorthosite (5d)
Coherence (intergranular): Coherent
Shape: Subrounded
Surface: Rough
Color: Pale yellowish gray
Special Features: Zap pits common
No. of Particles: 1 / Weight: 0.34g

Remarks: Rock rich in plagioclase but mafics and opaques are also present. Grain size is too fine to estimate percentages.



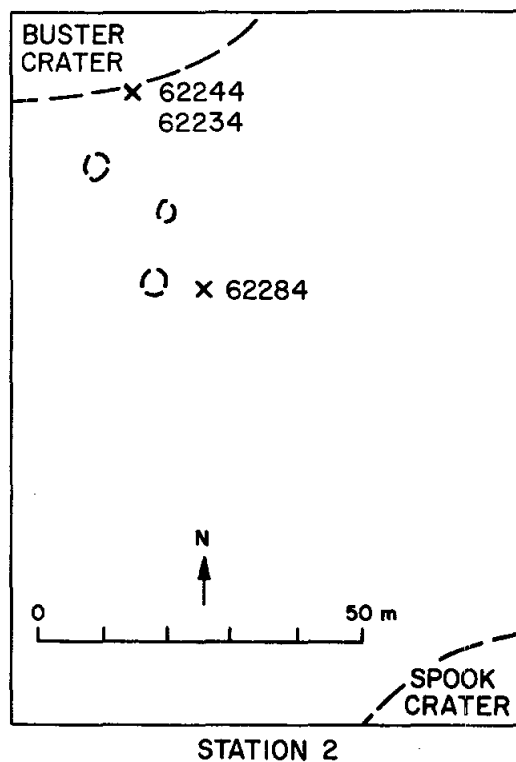

STATION 2

Station 2 is between Spook Crater and Buster Crater, both of which are less than 100 m in diameter. Of the two, Buster Crater is the younger, more sharply defined feature. It re-excavated ejecta from the Spook Crater event and probably penetrated to the underlying Cayley bedrock, fragments of which should be present in the rim. Sample 62284 is surface soil collected about 35 m SE of Buster Crater; samples 62244 and 62234 are from the crater rim.

SAMPLE 62284,1

Rock Type: Microbreccias (1a)
Coherence (intergranular): Very friable; shedding dust
Shape: Subrounded
Surface: Grainy
Color: Brown matrixes; small angular clasts, dark and light
Special Features: None
No. of Particles: 17/ Weight: 2.03g

SAMPLE 62284,2

Rock Type: Annealed microbreccias (1c)
Coherence (intergranular): Friable to coherent
Shape: Angular
Surface: One particle partially coated with brown vesicular glass
Color: Matrixes gray to black; clasts mainly white
Special Features: None
No. of Particles: 5 / Weight: 2.28g

SAMPLE 62284,3

Rock Type: Gray and white microbreccias (3a,3b)
Coherence (intergranular): Friable to coherent
Shape: Angular to subrounded
Surface: Vesicular glass on some surfaces
Color: Light gray to white
Special Features: Zap pits present
No. of Particles: 13/ Weight: 1.79g

SAMPLE 62284,4

Rock Type: Glassy particles (2)
Coherence (intergranular): Brittle
Shape: Angular to ropy
Surface: Vesicular; partly coated with dust and breccia
Color: Gray to milky white; vitreous to aphanitic
Special Features: None
No. of Particles: 2 / Weight: 0.29g

Remarks: One of these particles is a mass of vesicular ropy glass; the other is a fragment of a flow-banded vein from a microbreccia. It consists of light-colored feldspathic glass.

SAMPLE 62284,5

Rock Type: Fine-grained crystallines (4)
Coherence (intergranular): Tough
Shape: Angular, blocky
Surface: Tiny vesicles present in some particles
Color: Light brown to gray and off-white
Special Features: Many faces coated with dust or microbreccia
No. of Particles: 15/ Weight: 3.00g

SAMPLE 62284,6

Rock Type: Anorthosites (6a, 6b)
Coherence (intergranular): Coherent
Shape: Subangular to rounded
Surface: Smooth to pebbly; with patches of colorless glass crust
Color: Chalky white to gray and white
Special Features: A few zap pits lined with colorless glass
No. of Particles: 11/ Weight: 2.26g

Remarks: These particles range from microbreccias with angular white or gray clasts in a white matrix to very fine-grained chalky materials.

SAMPLE 62244,1

Rock Type: Microbreccias (1a)
Coherence (intergranular): Very friable; shedding soil
Shape: Subrounded
Surface: Dusty; dark brown glass on some surfaces
Color: Matrixes light brown
Special Features: None
No. of Particles: 48/ Weight: 8.70g

Remarks: Most of these particles are friable soil breccias (1a)
but 2 are more competent gray-white breccias (3b)
and 2 are dense annealed breccias with black
matrixes and angular white clasts (1c).

SAMPLE 62244,2

Rock Type: Gray and white microbreccias (3a,3b)
Coherence (intergranular): Coherent with a few nonpenetrative
Shape: Angular to subrounded fractures
Surface: Smooth fractures; other surfaces rough
Color: Chalky white matrixes; grey clasts
Special Features: Rare glass-lined zap pits
No. of Particles: 7 / Weight: 1.55g

Remarks: Most of these particles consist predominantly of
white feldspar and could equally well be classified
as anorthositic microbreccias.

SAMPLE 62244,3

Rock Type: Glassy particles (2)
Coherence (intergranular): Brittle; conchoidal fracture
Shape: Irregular to spherical
Surface: Two particles vesicular; 2 smooth
Color: Gray, yellowish brown, and dark green
Special Features: White dust covering most of one particle
No. of Particles: 4 / Weight: 0.79g

Remarks: Particle a is a vesicular mass of greenish glass; particle b is a broken nodule of green aphanitic material coated with white soil on all surfaces except the fresh fracture; c is an aphanitic hollow spherule; d is a fragment of yellow-brown glass that is largely vitreous but has a smoothly rounded aphanitic upper surface abundantly marked with zap pits.

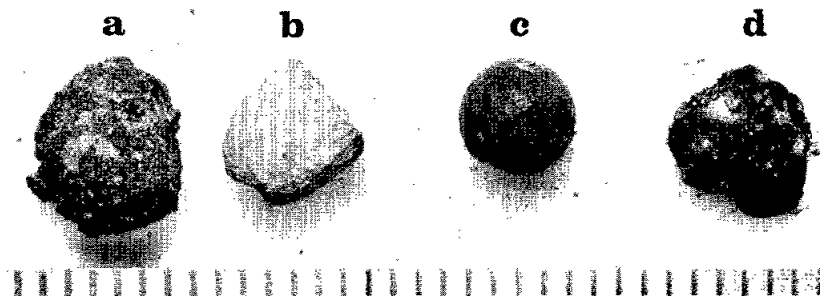

SAMPLE 62244,4

Rock Type: Fine-grained crystallines (4)
Coherence (intergranular): Tough
Shape: Angular, blocky
Surface: Smooth to rough and irregular
Color: Gray to brown and white
Special Features: Zap pits on some surfaces
No. of Particles: 17/ Weight: 3.14g

Remarks: Some particles are very dense to aphanitic, others fine-grained. Most appear to be re-crystallized microbreccias or glasses.

SAMPLE 62234,1

Rock Type: Microbreccias (1a)
Coherence (intergranular): Very friable and shedding
Shape: Rounded
Surface: Dusty
Color: Matrixes light brown; clasts light and dark
Special Features: A few small cavities present
No. of Particles: 4 / Weight: 0.40g



SAMPLE 62234,2

Rock Type: Annealed microbreccias (1c)
Coherence (intergranular): Coherent
Shape: Irregular
Surface: Rough, with thin glass crusts on some surfaces
Color: Light gray matrixes; light clasts
Special Features: Zap pits present
No. of Particles: 4 / Weight: 0.74g

62234,2

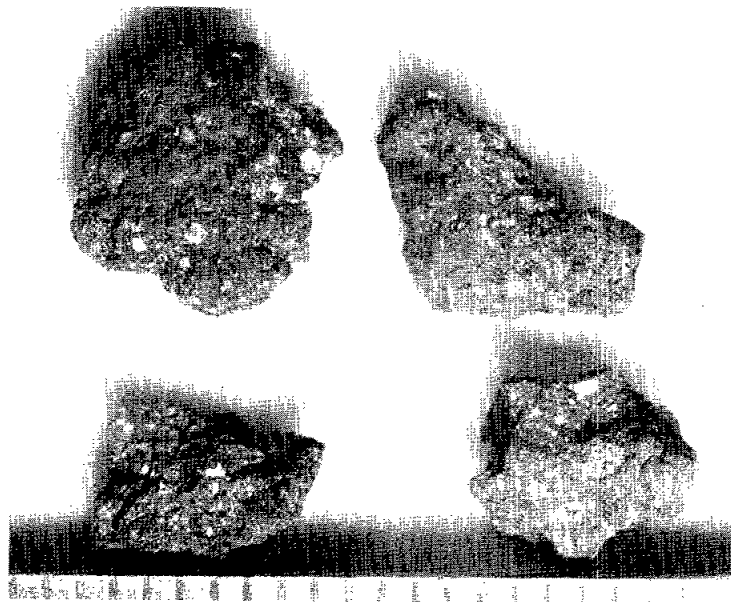

SAMPLE 62234,3

Rock Type: Glass-rich particles (2)
Coherence (intergranular): Brittle to tough
Shape: Irregular
Surface: Vesicular
Color: Gray to brown; vitreous to aphanitic
Special Features: Sparse zap pits
No. of Particles: 6 / Weight: 1.39g

Remarks: These are fragments of boiled glasses with an abundance of included soil and microbreccia.

SAMPLE 62234,4

Rock Type: Anorthositic microbreccias (5a)
Coherence (intergranular): Fairly coherent
Shape: Angular
Surface: Traces of glass and dust on some surfaces
Color: Chalky white groundmass; gray streaks and inclusions
Special Features: A few zap pits lined with colorless glass
No. of Particles: 10/ Weight: 2.31g

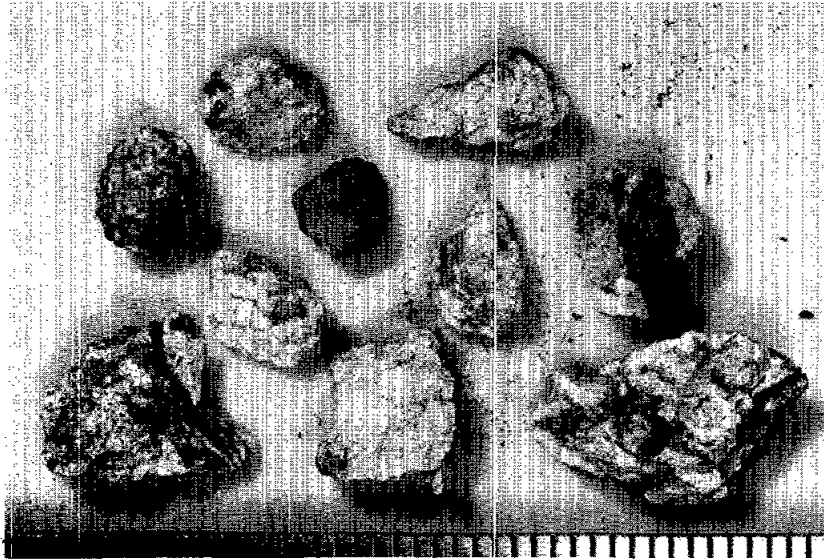

SAMPLE 62234,5

Rock Type: Fine-grained crystallines (4)
Coherence (intergranular): Tough, competent
Shape: Angular, blocky
Surface: Smooth; with minor vesicles and small vugs
Color: Medium-light gray
Special Features: A few zap pits
No. of Particles: 6 / Weight: 3.00g



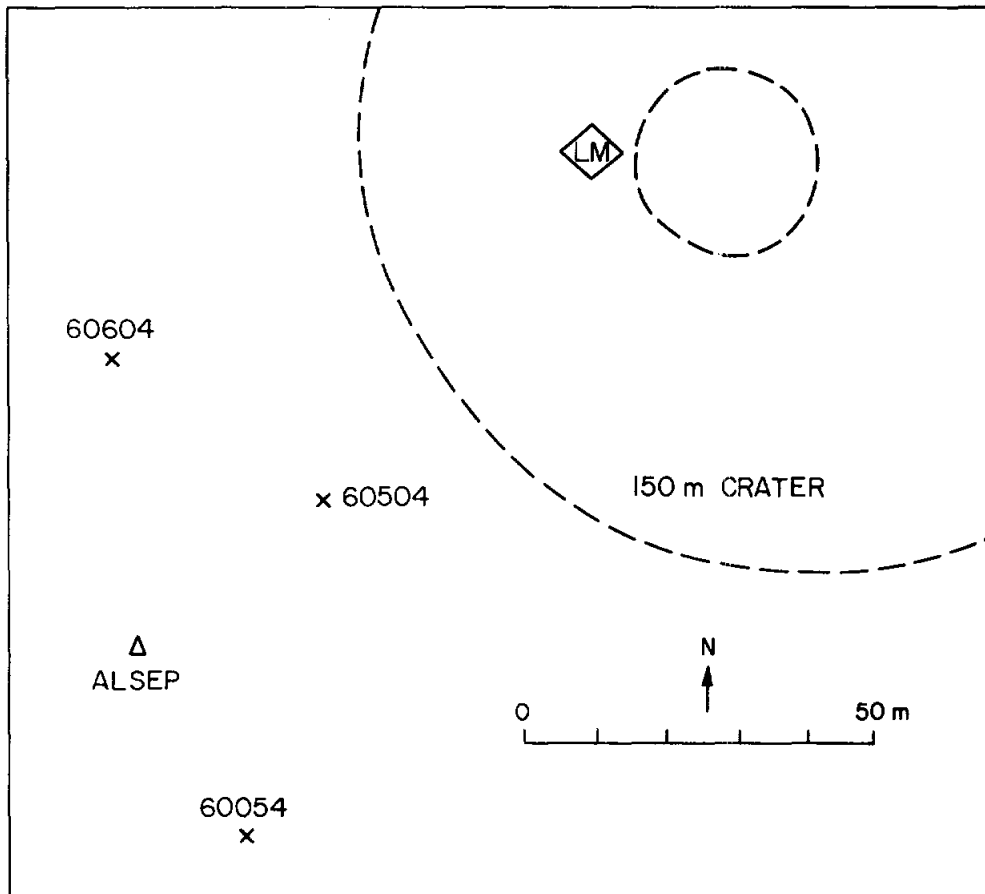

STATION 10 LM/ALSEP

Station 10 is on the Cayley Plains where Lunar Module Orion landed. It is an area of subdued craters with a relief of a few meters. The soils are generally gray with light streaks and patches of ejecta from South Ray Crater. The three samples in this collection were taken from rake sample sites located within 45 meters of the ALSEP package.

SAMPLE 60504,1

Rock Type: Anorthosites (5a,5b)
Coherence (intergranular): Friable to cohesive
Shape: Angular to subrounded
Surface: Rough
Color: White
Special Features: None
No. of Particles: 4 / Weight: 0.22g

Remarks: 3 particles are white clastic microbreccias;
1 particle is a chalky white anorthosite.

SAMPLE 60504,2

Rock Type: Microbreccias and glass-welded aggregates (1b,1c)
Coherence (intergranular): Friable to cohesive
Shape: Angular; irregular
Surface: Partially coated with brown, cindery glass
Color: Matrixes gray; clasts, gray and white
Special Features: None
No. of Particles: 22/ Weight: 3.48g

Remarks: Most of these breccias are lightly annealed. One is strongly annealed and has white clasts in a black, aphanitic matrix.

SAMPLE 60504,3

Rock Type: Fine-grained crystallines (4)
Coherence (intergranular): Tough
Shape: Angular to rounded (nodular)
Surface: Rough, sugary
Color: Light gray to brown
Special Features: Tiny vesicles in some particles
No. of Particles: 7 / Weight: 1.51g

Remarks: Four particles are fine-grained, nondescript, angular fragments; three are irregular and have small vesicles.

SAMPLE 60504,4

Rock Type: Recrystallized microbreccias (1c)
Coherence (intergranular): Tough
Shape: Irregular
Surface: Rough; sugary to vesicular
Color: Dark gray with light relict clasts
Special Features: Lenticular mass of white feldspar in one particle
No. of Particles: 6 / Weight: 1.01g

Remarks: These particles differ from those of 60504,3
in having visible relict clasts in a dark
aphanitic matrix.

SAMPLE 60054,1

Rock Type: Microbreccia (1a)
Coherence (intergranular): Friable
Shape: Rounded
Surface: Partially coated with brown vesicular glass
Color: Matrix, light brown; inclusions, light and dark
Special Features: None
No. of Particles: 1 / Weight: 0.22g



SAMPLE 60054,2

Rock Type: Glassy particle (2)
Coherence (intergranular): Brittle; conchoidal fracture
Shape: Irregular, with smooth flow surface
Surface: Thinly coated with fine dust
Color: Gray; aphanitic
Special Features: One edge highly vesicular
No. of Particles: 1 / Weight: 0.30g



SAMPLE 60054,3

Rock Type: Anorthositic microbreccias (5a)
Coherence (intergranular): Friable; a few penetrative fractures
Shape: Subangular to rounded
Surface: Powdery
Color: Matrixes chalky white; inclusions, colorless, gray, white
Special Features: None
No. of Particles: 10/ Weight: 3.00g

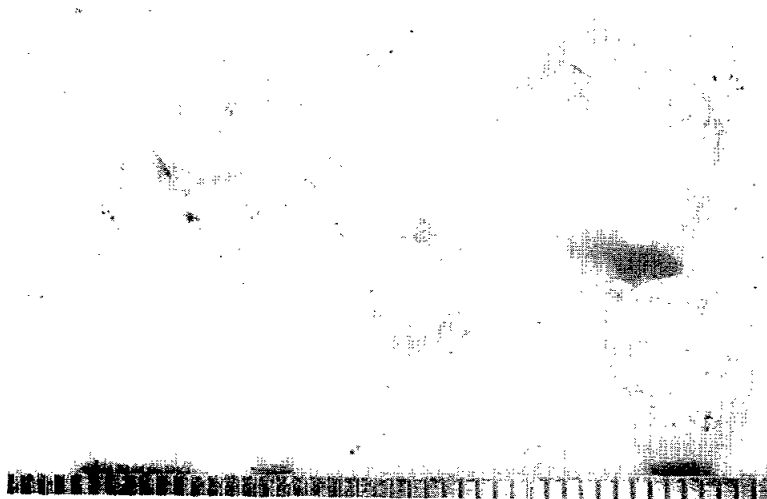

SAMPLE 60054,4

Rock Type: Annealed gray and white microbreccias (3b)
Coherence (intergranular): Coherent; some penetrative fractures
Shape: Angular
Surface: Rough
Color: Matrixes gray; clasts mostly white
Special Features: Vesicular glass coating one particle
No. of Particles: 2 / Weight: 0.42g



SAMPLE 60054,5

Rock Type: Fine-grained crystallines (4)
Coherence (intergranular): Tough
Shape: Angular and blocky to irregular
Surface: Fractures smooth, other surfaces rough
Color: Various shades of gray and light brown
Special Features: Some particles vesicular
No. of Particles: 14/ Weight: 2.40g

Remarks: These particles include a broad spectrum of the types found in category 4. They range from fine-grained to aphanitic; smooth to vesicular. Several particles are coated with fine white dust and appear to be clasts or nodules disaggregated from anorthositic microbreccias. The vesicular particles are probably crystallines derived from glasses that were quenched in an early stage of crystallization or have devitrified.

60054,5

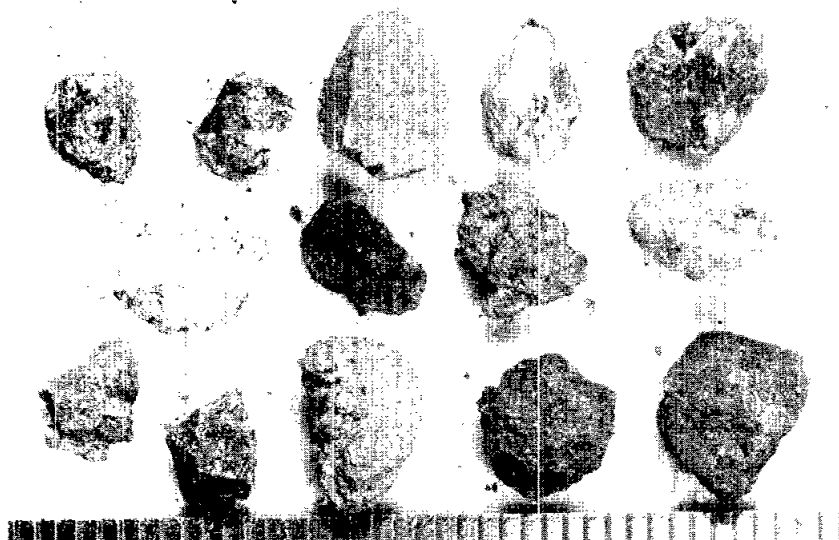

SAMPLE 60604,1

Rock Type: Microbreccias and glass-welded aggregates (1a,1b,1c)
Coherence (intergranular): Friable to coherent
Shape: Angular, irregular
Surface: Rough, partially coated with glass
Color: Matrixes gray to light brown; clasts predominantly light
Special Features: None
No. of Particles: 13/ Weight: 1.15g

60604,1



SAMPLE 60604,2

Rock Type: Gray crystallines (6a)
Coherence (intergranular): Coherent
Shape: Angular, blocky
Surface: Rough, granular
Color: Light gray
Special Features: Sparse zap pits
No. of Particles: 3 / Weight: 0.61g

Remarks: Plagioclase is predominant in these particles. The textures are fine-grained, equigranular except for the particle at lower right, which includes one large feldspar crystal 4 mm long embedded in the fine groundmass.

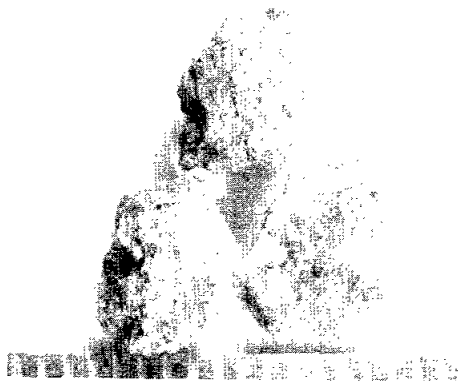

SAMPLE 60604,3

Rock Type: Glassy particles (2)
Coherence (intergranular): Brittle
Shape: Ropy and irregular to nearly spherical
Surface: Rough; coated with dust and soil particles
Color: Dark gray; vitreous to aphanitic
Special Features: None
No. of Particles: 3 / Weight: 0.54g



SAMPLE 60604,4

Rock Type: Fine-grained crystallines (4)
Coherence (intergranular): Tough
Shape: Blocky to irregular
Surface: Rough
Color: Dark gray
Special Features: Zap pits on some surfaces
No. of Particles: 7 / Weight: 1.37g

Remarks: These are very fine-grained crystallines, each of which appears fairly homogeneous excepting for a few irregular white blotches suggestive of recrystallized white clasts. The more irregular particles have tiny vesicles.



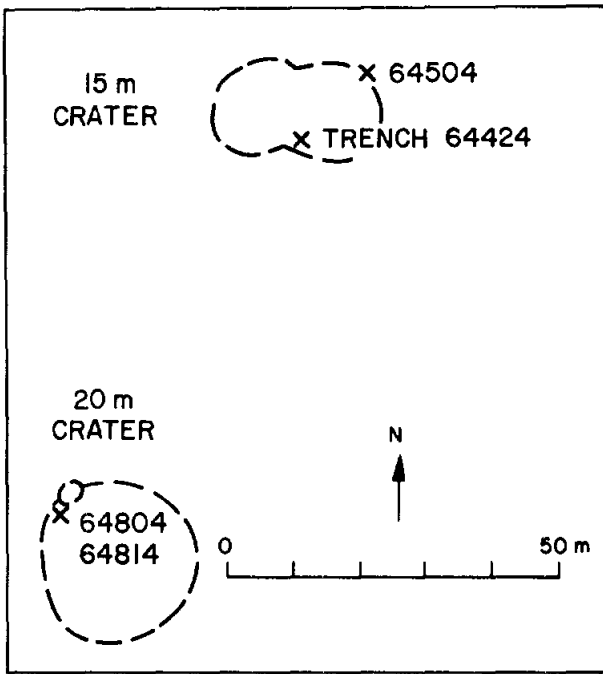

STATION 4

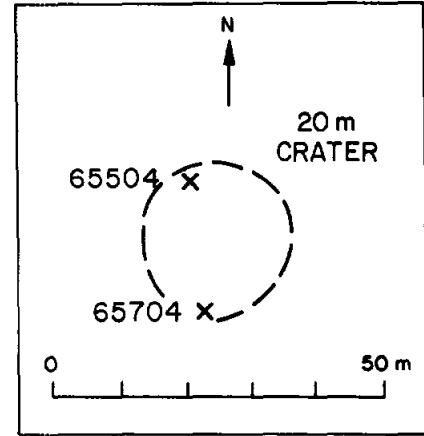

STATION 5

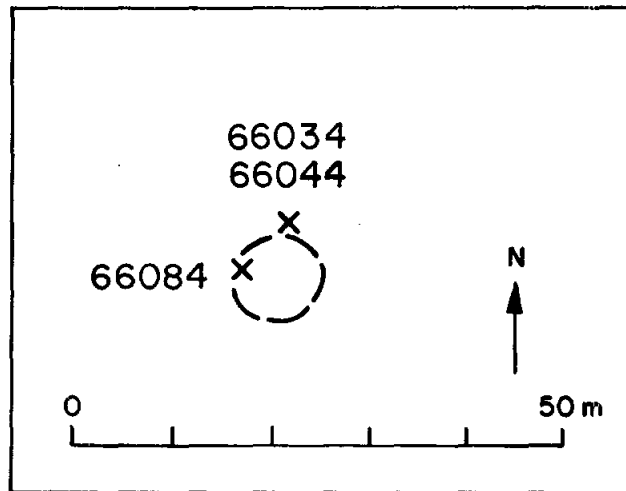

STATION 6

Stations 4, 5, and 6 are on the NW slope of Stone Mountain, a prominent feature that rises above the Cayley Plains about 3.5 km south of the landing site. Advance geologic interpretations of aerial photographs suggested that Stone Mountain consists of the Descartes Formation, an ancient pre-Imbrian terra material, and that the plains are of the younger, smoother Imbrian Cayley Formation. On the EVA, however, the astronauts did not observe any perceptible change in color or character of the regolith as they left the plains and started up the mountain.

Station 4 is the highest of the three on the mountain. At this site the regional slope is 10-15° to the NW and the regolith is blocky with ejecta from nearby South Ray Crater. Sample 64504 was taken from a rake sample site at the rim of a small 15 m crater, and sample 64424 is from the bottom of a shallow trench in the south rim of the same crater. No evidence of layering was observed in the trench wall. Samples 64804 and 64814 were collected at a rake sample site in the rim of another small crater some 60 m SW of the first.

Station 5 is 0.5 km down the slope from Station 4. It is on a bench, about 50 m wide with a northward slope of about 5°. Samples 65504 and 65704 were taken from rake sample sites at the rim of a small 20 m crater on the bench. Sample 65904 was collected from 15 cm beneath the surface at a site not specified on the available plainmetric maps.

Station 6 is on the lowest bench on Stone Mountain where the regional slope is less than 5°. Samples 66034 and 66044 were collected from the rim of a very small crater. Sample 66084 is from a patch of white material on the surface of the regolith.

SAMPLE 64504,1

Rock Type: Microbreccias (1a)
Coherence (intergranular): Friable to very friable
Shape: Subangular to rounded
Surface: Grainy
Color: Matrixes light brown to gray
Special Features: Glassy coatings on some surfaces
No. of Particles: 20/ Weight: 4.16g

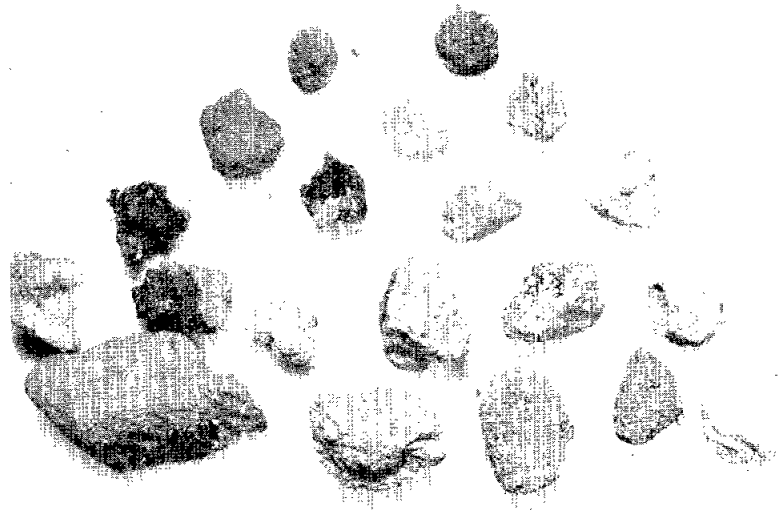

SAMPLE 64504,2

Rock Type: Gray and white microbreccias (3a, 3b)
Coherence (intergranular): Friable to coherent
Shape: Angular
Surface: Rough and irregular
Color: White clasts in dense gray matrixes
Special Features: - Some veinlets of dark glass
No. of Particles: 19/ Weight: 4.39g

64504,2



SAMPLE 64504,3

Rock Type: Annealed gray and white microbreccias (3b)
Coherence (intergranular): Friable to coherent
Shape: Angular
Surface: Rough
Color: Variegated gray and white
Special Features: Thin coating of glass on some surfaces
No. of Particles: 9 / Weight: 2.12g

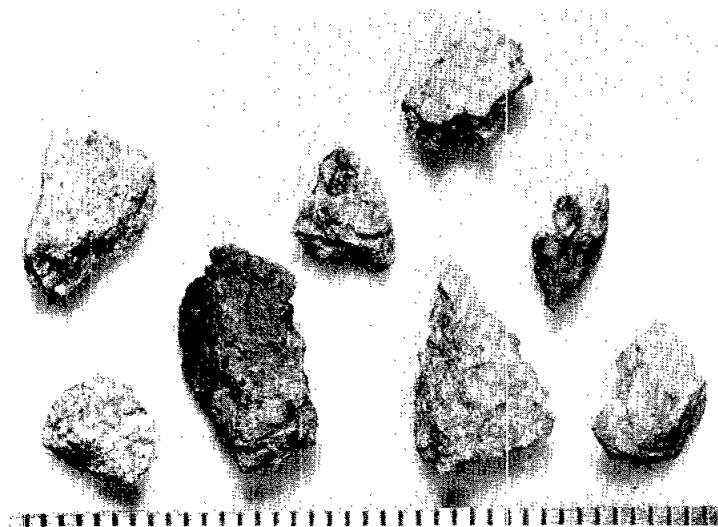

SAMPLE 64504,4

Rock Type: Fine-grained crystallines (4)
Coherence (intergranular): Tough
Shape: Angular, blocky to irregular
Surface: Textures vary from aphanitic and flinty, to sugary
Color: Gray to reddish brown
Special Features: Minute vesicles in some particles
No. of Particles: 23/ Weight: 4.41g

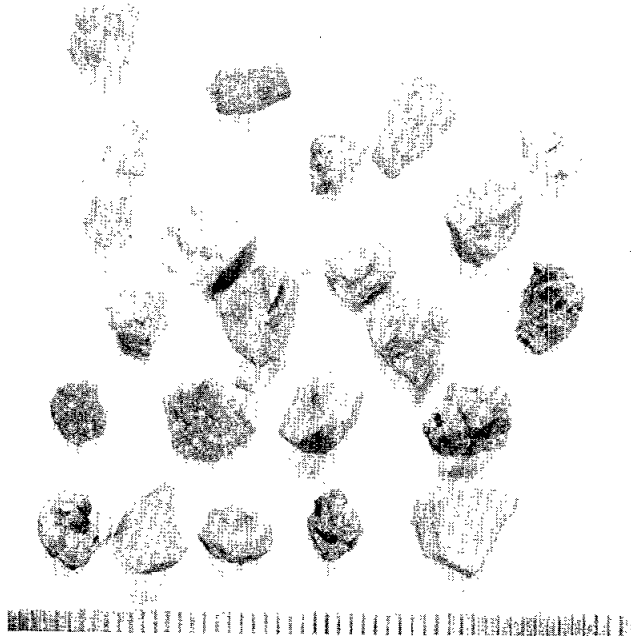

SAMPLE 64504,5

Rock Type: Anorthosites (5a,5c)
Coherence (intergranular): Friable to coherent
Shape: Angular to subrounded
Surface: Textures: some fragmental, others aphanitic
Color: Predominantly chalky white; sparse gray and white inclusions
Special Features: None
No. of Particles: 22/ Weight: 3.47g

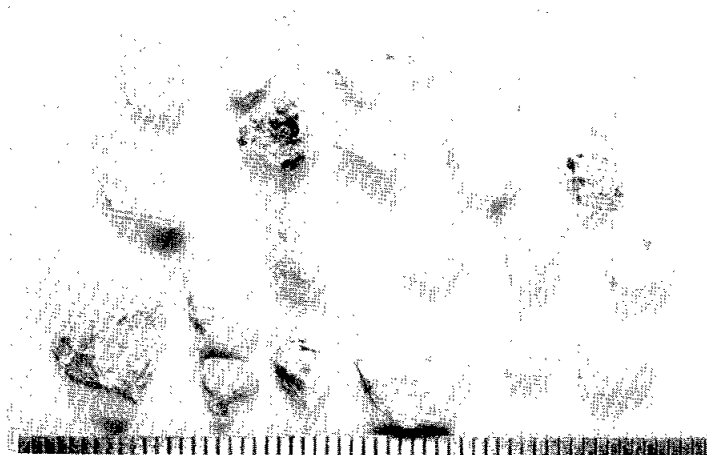

SAMPLE 64504,6

Rock Type: Exceptional particles (7)
No. of Particles: 5 / Weight: 1.05g

Remarks: Particles a and c are veins of black glass with attached fragments of gray microbreccias. Particle A is mostly vitreous but has a chilled region of gray aphanitic material.

Particle b is a small dust-coated nodule with one broken surface exposing green aphanitic material with a waxy luster; the green material may be olivine or may be devitrified glass.

Particle d is a tough, elongate nodule coated with fine soil. It is not fractured and its character is unknown.

Particle e is an angular fragment of white translucent feldspar glass.

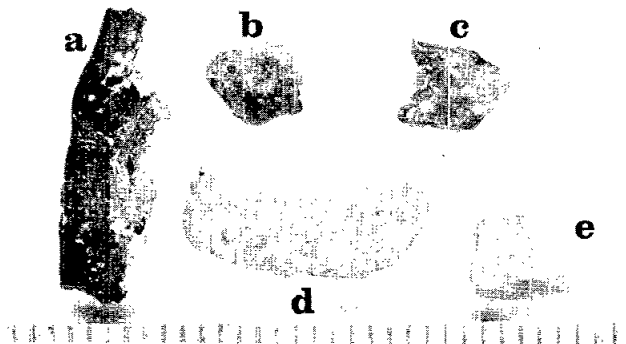

SAMPLE 64504,7

Rock Type: Anorthosites and gabbroic anorthosites (5c,5d)
Coherence (intergranular): Coherent; deep fractures in 2 particles
Shape: Angular
Surface: Rough; 1 particle soil-coated
Color: Light gray to yellowish white
Special Features: See Remarks
No. of Particles: 4 / Weight: 1.52g

Remarks: Particle **a** is a gray vesicular mass of feldspar laths with a rough surface coated with fine dust. Some of the vesicles contain small metallic globules.

Particles **b** and **c** are gabbroic anorthosites with approximately 85% plagioclase and 15% mafic silicates including yellow olivine and cinnamon pyroxenes.

Particle **d** is a fine-grained, equigranular, sugary anorthosite.

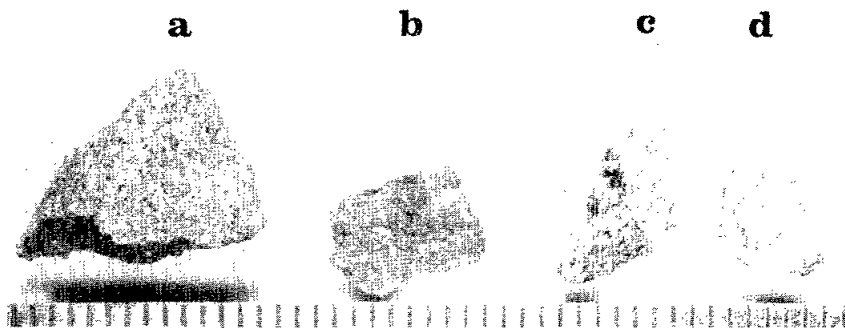

SAMPLE 64424,1

Rock Type: Microbreccias (1a)
Coherence (Intergranular): Very friable
Shape: Subangular
Surface: Grainy; partially coated with cindery glass
Color: Matrixes light brown; clasts gray and white
Special Features: None
No. of Particles: 3 / Weight: 0.29g

SAMPLE 64424,2

Rock Type: Shocked anorthosites (5b)
Coherence (intergranular): Friable, with non-penetrative fractures
Shape: Angular
Surface: Slabby, with thin patches of brown to colorless glass
Color: Chalky white matrixes; dark gray angular inclusions
Special Features: A few glass-lined zap pits
No. of Particles: 2 / Weight: 0.68g

Remarks: These particles appear to be anorthositic rocks that were shocked in situ. Matrix and inclusions are both very fine-grained to aphanitic.

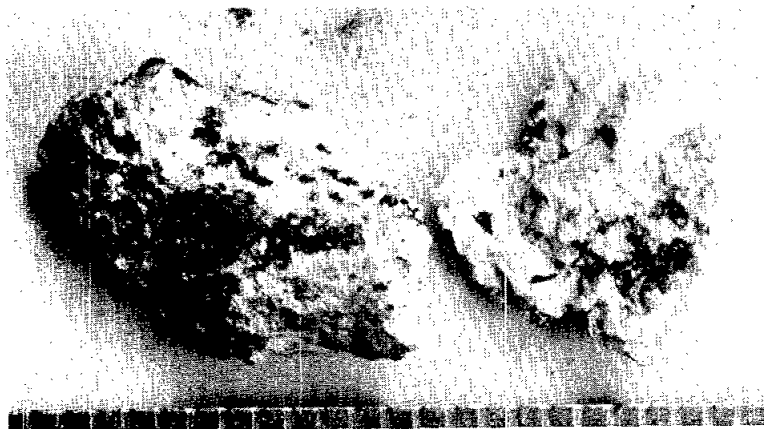

SAMPLE 64424,3

Rock Type: Microbreccia, partially annealed (1c)
Coherence (intergranular): Friable; with penetrative fracturing
Shape: Irregular
Surface: Rough
Color: Matrix gray; clasts white or gray and aphanitic
Special Features: None
No. of Particles: 1 / Weight: 0.15g



SAMPLE 64424,4

Rock Type: Fine-grained crystallines (4)
Coherence (intergranular): Coherent (to tough)
Shape: Blocky, angular
Surface: Smooth to rough, sugary
Color: Light gray to light brown
Special Features: Relict clasts visible in one particle
No. of Particles: 4 / Weight: 0.64g

Remarks: The particle at lower left is aphanitic, has small vesicles, and appears to be a recrystallized glass; the one at lower right is a recrystallized microbreccia.



SAMPLE 64424,5

Rock Type: Uncertain (7); crystalline or glass-rich
Coherence (intergranular): Tough
Shape: Subrounded, equant
Surface: Soil coated except for one small fracture
Color: Light green
Special Features: None
No. of Particles: 1 / Weight: 0.04g

Remarks: This particle is a nodular mass of either an aphanitic green mafic rock or a devitrified green glass.

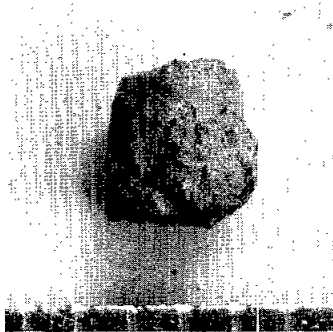

SAMPLE 64814,1

Rock Type: Microbreccias (1a,1c)
Coherence (intergranular): Friable to cohesive
Shape: Angular to rounded
Surface: Rough; partially coated with brown cindery glass
Color: Matrixes light brown; clasts light and dark
Special Features: None
No. of Particles: 5 / Weight: 0.77g

Remarks: The particle at upper left is very friable and rounded by abrasion. The angular particle at lower right is strongly annealed and has a black matrix with white clasts. The other three are lightly annealed.

64814,1

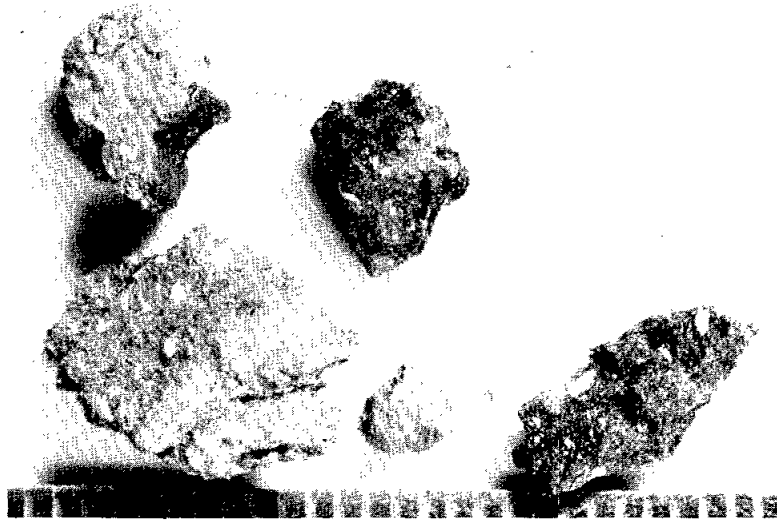

SAMPLE 64814,2

Rock Type: Glass (2)
Coherence (intergranular): Tough
Shape: Irregular
Surface: Rough, vesicular
Color: Brown
Special Features: None
No. of Particles: 1 / Weight: 0.12g

Remarks: The particle is mainly cindery glass but includes an abundance of dust and soil fragments.

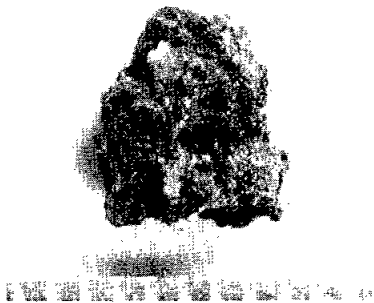

SAMPLE 64814,3

Rock Type: Fine-grained crystallines (4)
Coherence (intergranular): Tough
Shape: Angular
Surface: Relatively smooth with a few small vesicles
Color: Light to medium gray
Special Features: None
No. of Particles: 8 / Weight: 1.59g

Remarks: Particle a has white relict clasts and is a recrystallized microbreccia; the others are homogeneous, nondescript.



SAMPLE 64814,4

Rock Type: Gabbroic anorthosite (5d)
Coherence (intergranular): Cohesive
Shape: Subrounded
Surface: Rough, granular
Color: Light yellowish white
Special Features: Soil coating one surface
No. of Particles: 1 / Weight: 0.16g

Remarks: Macroscopically, this particle appears to contain white plagioclase (about 60%), brownish-yellow pyroxene (about 40%); opaques about 1%.



SAMPLE 64804,1

Rock Type: Microbreccias and glass-welded aggregates (1a,1b,1c)
Coherence (intergranular): Most breccias very friable and shedding dust; 3 are partially annealed and coherent

Color: Matrixes gray; clasts range from dark to light

Special Features: None

No. of Particles: 12/ Weight: 1.83g

Remarks: Six of these particles are friable soil breccias with fine-grained powdery matrixes; these are rounded from constant shedding of dust. Three particles (upper left) are glass-welded aggregates of similar material. Three others, including the two largest ones, are partially annealed and have coherent, dark gray matrixes with angular white clasts plus inclusions of a yellow mafic mineral.

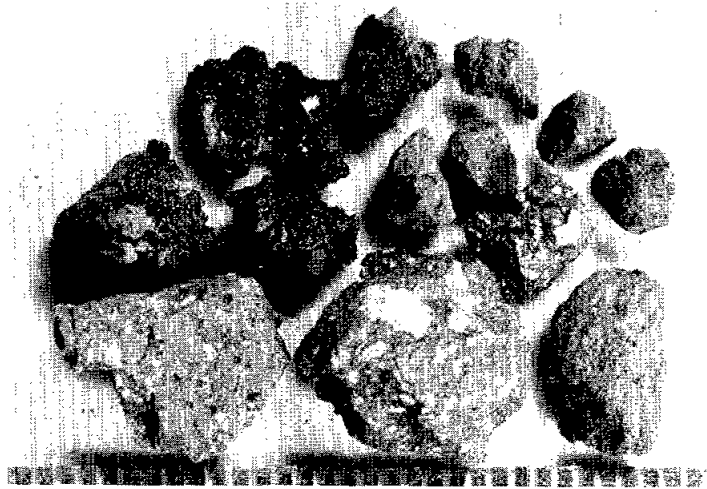

SAMPLE 64804,2

Rock Type: Gray and white microbreccias (3b)
Coherence (intergranular): Friable to coherent
Shape: Angular
Surface: Rough
Color: Mottled gray and white
Special Features: None
No. of Particles: 14/ Weight: 2.93g

Remarks: These particles grade from friable breccias with fine-grained white matrixes and grey inclusions to more coherent rocks with a webbed gray and white texture.

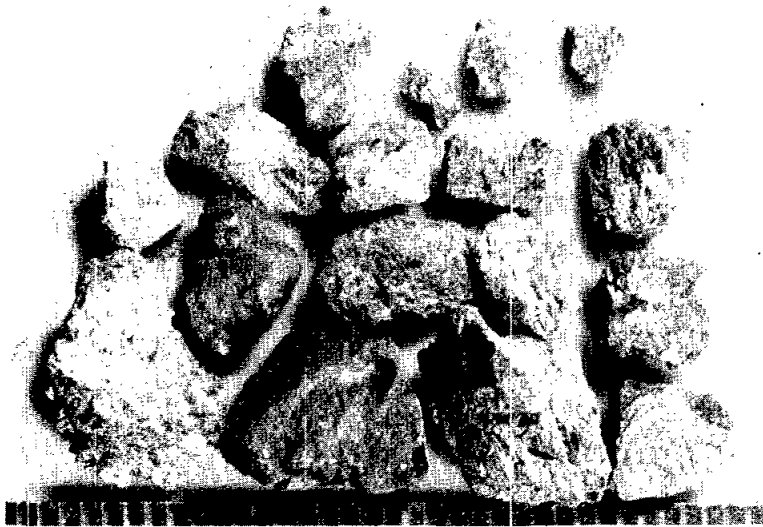

SAMPLE 64804,3

Rock Type: Gabbroic anorthosites (5d)
Coherence (intergranular): Coherent
Shape: Angular
Surface: Rough, with small vesicles in some particles
Color: Light beige
Special Features: Honey yellow crystals in small rounded vugs
No. of Particles: 4 / Weight: 1.04g

Remarks: Particles are predominantly of plagioclase, but mafic silicates and tiny opaque grains are also present.

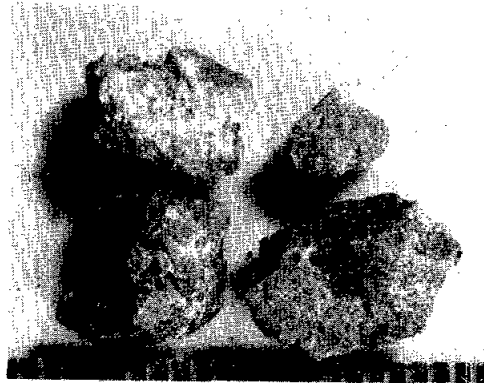

SAMPLE 64804,4

Rock Type: Anorthosites (5c)
Coherence (intergranular): Tough
Shape: Irregular
Surface: Fine-grained, sugary, with small vugs
Color: White
Special Features: None
No. of Particles: 2 / Weight: 0.29g

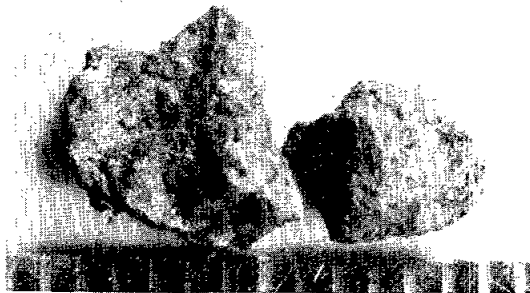

SAMPLE 65504,1 (undusted)

Rock Type: Glass-welded aggregates (lb)
Coherence (intergranular): Brittle glass; very friable soil
Shape: Irregular
Surface: Vesicular; coated with dust
Color: Dark brown cindery glass; light brown soil
Special Features: None
No. of Particles: 2 / Weight: 0.99g

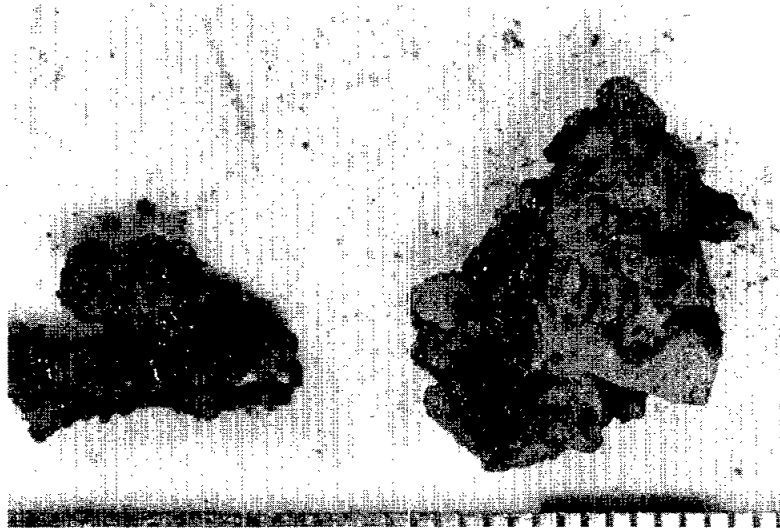

SAMPLE 65504,2 (undusted)

Rock Type: Gray and white microbreccias (3a) (?)
Coherence (intergranular): Coherent
Shape: Nodular to angular
Surface: Dust-coated
Color: Uncertain because of gray dust
Special Features: Small vugs in 3 particles
No. of Particles: 6 / Weight: 2.04g

SAMPLE 65504,3 (undusted)

Rock Type: Fine-grained crystallines (4)
Coherence (intergranular): Tough
Shape: Angular
Surface: Dust-coated
Color: Probably gray
Special Features: None
No. of Particles: 2 / Weight: 0.54g

SAMPLE 65504,4 (undusted)

Rock Type: Very friable clods of soil.
Weight: 16.77g

Remarks: Although this sample began in the 4-10 mm size range, most of it disaggregated to finer materials on gentle handling. None of the large clods in the photograph are coherent enough to survive transportation to another laboratory.

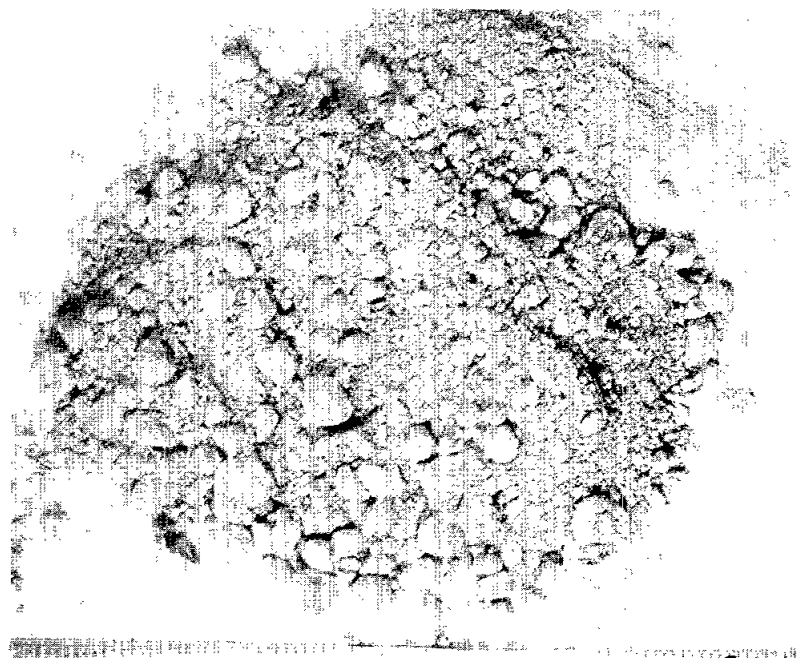

SAMPLE 65704,1

Rock Type: Microbreccias (3a)
Coherence (intergranular): Friable to fairly coherent
Shape: Subangular
Surface: Splattered with droplets of black glass
Color: Matrixes white, clasts white and gray
Special Features: None
No. of Particles: 2 / Weight: 0.83g



SAMPLE 65704,2

Rock Type: Gabbroic anorthosite (?)
Coherence (intergranular): Tough
Shape: Subangular
Surface: Coated with fine dust
Color: White
Special Features: None
No. of Particles: 1 / Weight: 0.17g

Remarks: Rock is too fine-grained to distinguish separate minerals macroscopically, but a small percentage of yellow mafics and rare opaques appear to be present in addition to the dominant white plagioclase.

SAMPLE 65704,3

Rock Type: Gray and white microbreccia (recrystallized) (3b)
Coherence (intergranular): Coherent
Shape: Subrounded
Surface: Liberally spattered with droplets of black glass
Color: Gray matrix with white splotchy inclusions
Special Features:
No. of Particles: 1 / Weight: 0.11g

SAMPLE 65904,1

Rock Type: Microbreccias and glass-welded aggregates (1a,1b)
Coherence (intergranular): Very friable
Shape: Irregular
Surface: Partially coated with brown cindery glass
Color: Matrixes light brown; clasts both light and dark
Special Features: None
No. of Particles: 24/ Weight: 3.12g

SAMPLE 65904,2

Rock Type: Glass bomblet (2)
Coherence (intergranular): Fragile
Shape: Bullet-shaped
Surface: Rough, aphanitic, and coated with fine dust and soil
Color: Dark brown
Special Features: Hollow; vitreous interior
No. of Particles: 1 / Weight: 0.31g



SAMPLE 65904,3

Rock Type: Annealed Gray and white microbreccias (3b)
Coherence (intergranular): Coherent
Shape: Angular
Surface: Rough; numerous small vesicles
Color: Gray mottled with white
Special Features: Zap pits on several particles
No. of Particles: 11 / Weight: 3.01g

Remarks: Two particles include large clasts of chalky white anorthosite; others appear to be monomict clastic breccias.



SAMPLE 65904,4

Rock Type: Fine-grained crystallines (4)
Coherence (intergranular): Friable to coherent
Shape: Angular
Surface: A few vesicles in an aphanitic to fine-grained texture
Color: Gray to light brown
Special Features: One fragment almost shattered from zap-pitting
No. of Particles: 9 / Weight: 2.13g

SAMPLE 65904,5

Rock Type: Gabbroic anorthosites (5d)
Coherence (intergranular): Coherent
Shape: Angular, blocky
Surface: Medium-grained; sugary
Color: Yellowish-white
Special Features: A few glass-lined zap pits
No. of Particles: 2 / Weight: 0.28g

Remarks: These crystallines are polymineralic with plagioclase predominant, yellowish mafics minor, and tiny black opaque accessories.

SAMPLE 66034,1

Rock Type: Microbreccia, (lightly annealed) (1c)
Coherence (intergranular): Friable, shedding small chips
Shape: Subangular
Surface: Grainy
Color: Matrix light brown; clasts angular, mainly white and gray
Special Features: One shallow glass-lined cavity
No. of Particles: 1 / Weight: 1.07g

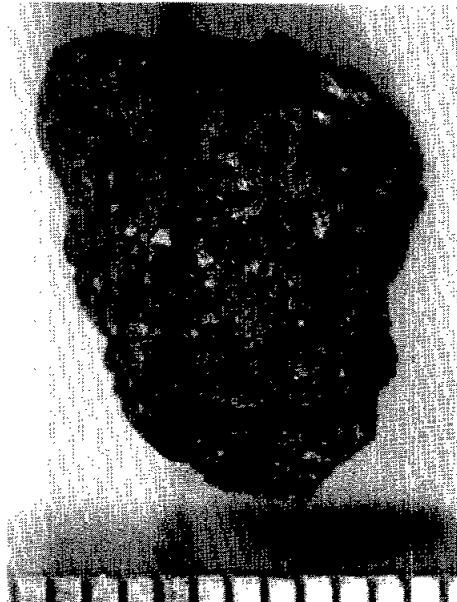

SAMPLE 66034,2

Rock Type: Compound particles: white microbreccias and glass (3a)
Coherence (intergranular): Breccias friable; glass brittle
Shape: Irregular
Surface: Breccias grainy; glass vesicular
Color: Breccias white with gray clasts; glass gray to black
Special Features: None
No. of Particles: 4 / Weight: 2.16g

Remarks: 3 particles are mainly vitreous to aphanitic dark glass with attached fragments of friable white microbreccia; one is a detached fragment of white breccia.

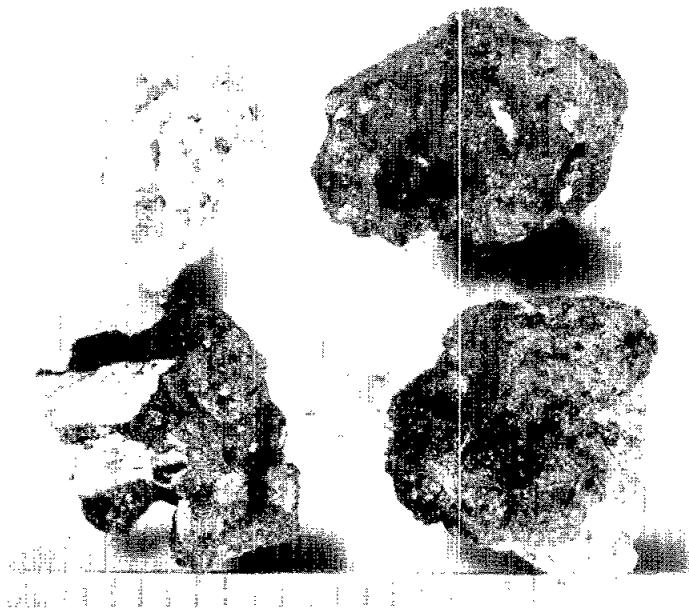

SAMPLE 66044,1 (undusted)

Rock Type: Glassy particles (2)
Coherence (intergranular): Brittle; conchoidal fracture
Shape: 2 spherules; 11 jagged vesicular fragments
Surface: Largely coated with fine dust
Color: Dark gray
Special Features: Zap pits common; small spherules on larger ones
No. of Particles: 13/ Weight: 3.13g

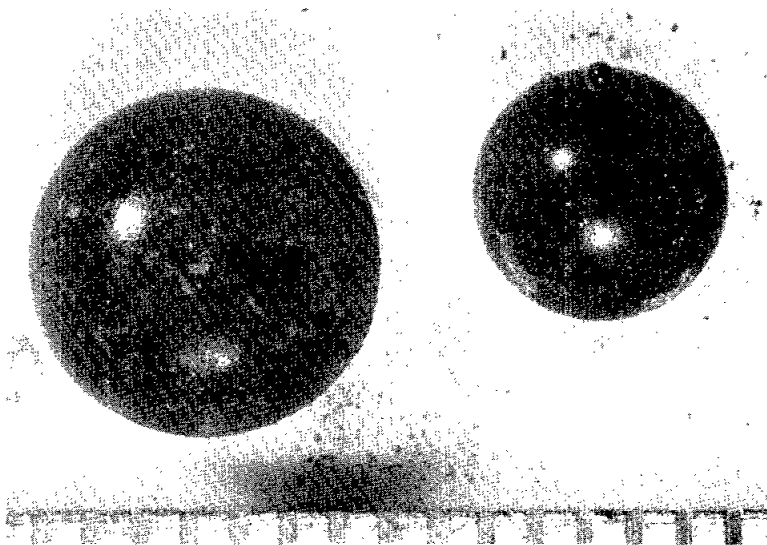
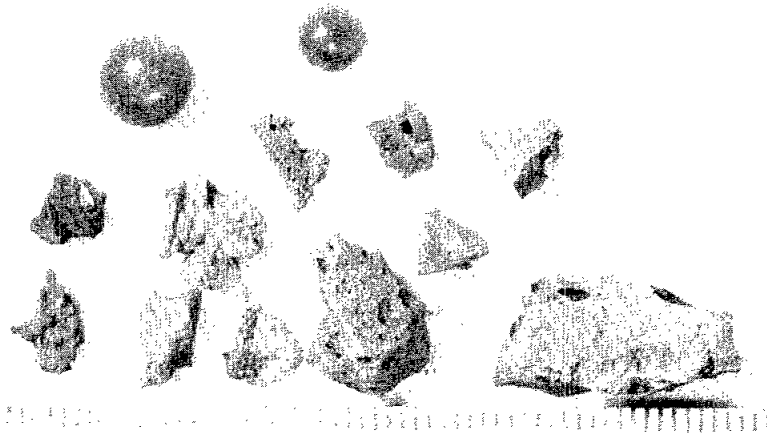

SAMPLE 66044,2 (undusted)

Rock Type: Microbreccias and glass-welded aggregates (1a,1b)
Coherence (intergranular): Friable
Shape: Very irregular
Surface: Dusty to vesicular
Color: Matrixes light brown; glasses brown
Special Features: None
No. of Particles: 15/ Weight: 3.09g

Remarks: Most particles are soil breccias with glassy crusts;
a few consist mainly of cindery glass.

SAMPLE 66044,3 (undusted)

Rock Type: Crystalline anorthosites (5c)
Coherence (intergranular): Coherent to tough
Shape: Angular, blocky
Surface: Smooth to rough, granular
Color: White to light gray
Special Features: Small vesicles in some grains
No. of Particles: 21/ Weight: 2.64g

Remarks: Most of these particles are very fine-grained,
homogeneous and nondescript. One particle is
partly enclosed within a gray microbreccia.

SAMPLE 66044,4 (undusted)

Rock Type: Fine-grained crystallines (4)
Coherence (intergranular): Tough
Shape: Angular to rounded
Surface: Rough with a few rounded vesicles
Color: Medium gray
Special Features: None
No. of Particles: 3 / Weight: 0.42g

SAMPLE 66044,5 (undusted)

Rock Type: Anorthosites: A. Microbreccia (5a); B. Crystalline (5c)
Coherence (intergranular): A. Friable; B. Tough
Shape: Angular
Surface: A. Very rough; B. Relatively smooth
Color: White
Special Features: A. Rust spots and yellow coating
No. of Particles: 2 / Weight: 0.70g

Remarks: Particle A is an anorthositic microbreccia with a white matrix and gray and white angular clasts. One surface has several irregular patches of red-brown rust plus an overall coating of pale sulfur-yellow.

Particle B is a fine-grained equigranular crystalline with a sugary texture.

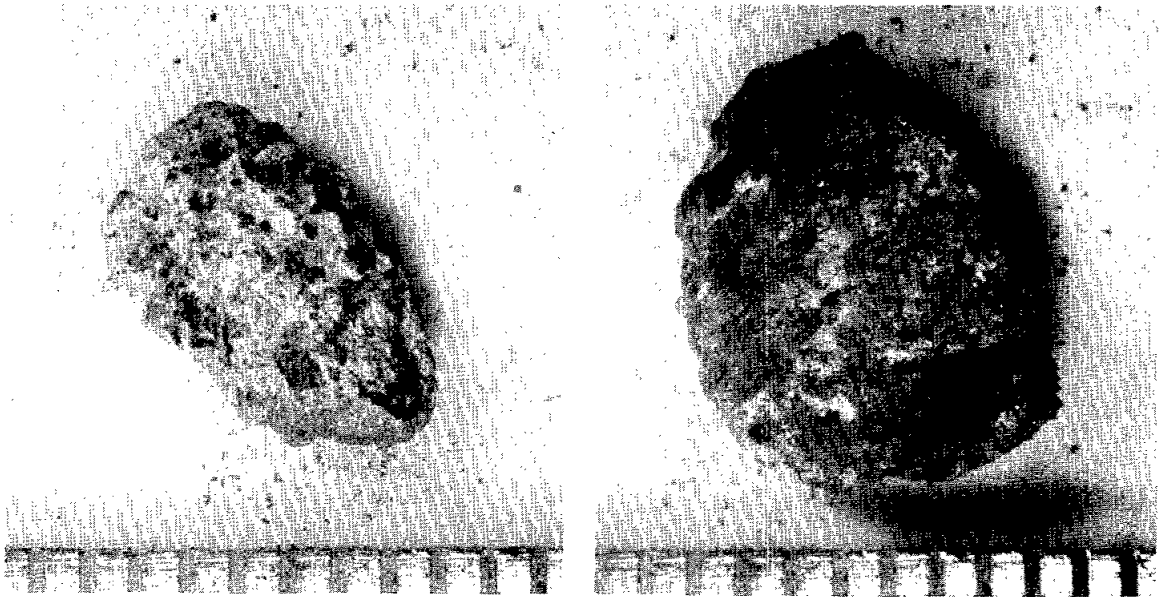

A

B

SAMPLE 66084,1 (undusted)

Rock Type: Microbreccias and glass-welded aggregates (1a,1b)
Coherence (intergranular): Very friable
Shape: Irregular
Surface: Breccias; grainy; glass, vesicular
Color: Brown matrixes; brown cindery glass
Special Features: None
No. of Particles: 4 / Weight: 0.42g

SAMPLE 66084,2 (undusted)

Rock Type: Fine-grained crystallines (4)
Coherence (intergranular): Tough
Shape: Angular
Surface: Rough, sintery on some particles
Color: Medium gray
Special Features: Tiny vesicles in most particles
No. of Particles: 5 / Weight: 0.96g

Remarks: The surface textures of these particles suggest that they are, or formerly were, glass-rich.



SAMPLE 66084,3 (undusted)

Rock Type: Gray and white microbreccias (3a,3b)
Coherence (intergranular): Friable to coherent
Shape: Subrounded
Surface: Rough, granular
Color: Matrixes light gray to white
Special Features: See Remarks
No. of Particles: 5 / Weight: 0.68g

Remarks: One particle (center) includes a large clast of pure white crystalline anorthosite with a fine-grained, sugary texture.



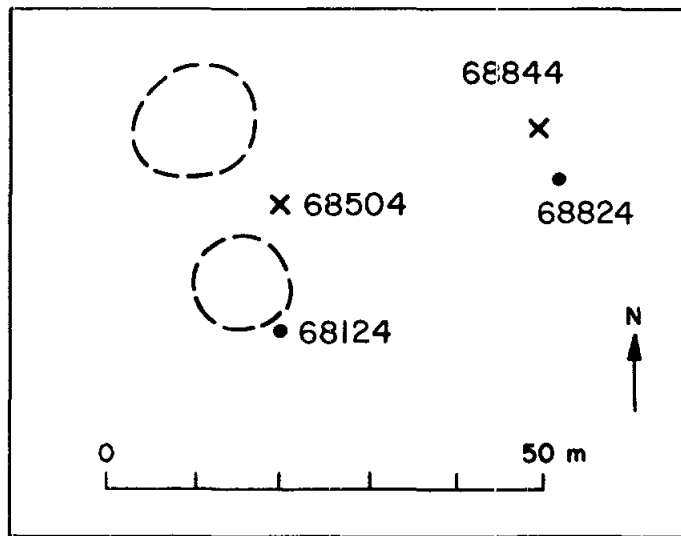

STATION 8

Station 8 is situated on a blanket of light-colored ejecta from South Ray Crater. Sample 68504 is from a rake sample site nearly midway between two small craters. Sample 68124 is from the rim of a small crater. Sample 68844 is the coarse fraction of a reference soil collected for comparison with Sample 68824 which is from a fillet banked against a breccia boulder.

SAMPLE 68504,1

Rock Type: Microbreccias and glass-welded aggregates (1a,1b)
Coherence (intergranular): Friable
Shape: Irregular
Surface: Some surfaces coated with brown cindery glass
Color: Matrixes gray, fine-grained; clasts light and dark
Special Features: None
No. of Particles: 12/ Weight: 1.20g

SAMPLE 68504,2

Rock Type: Glassy particles (2)
Coherence (intergranular): Brittle; conchoidal fracture
Shape: Irregular
Surface: Vesicular; partially coated with fine dust
Color: Dark gray; translucent to aphanitic
Special Features: Zap pits common
No. of Particles: 3 / Weight: 1.10g



SAMPLE 68504,3

Rock Type: Fine-grained crystallines (4)
Coherence (intergranular): Tough
Shape: Angular, blocky
Surface: Small gas cavities common; white dust on some surfaces
Color: Dark gray
Special Features: None
No. of Particles: 25/ Weight: 5.10g

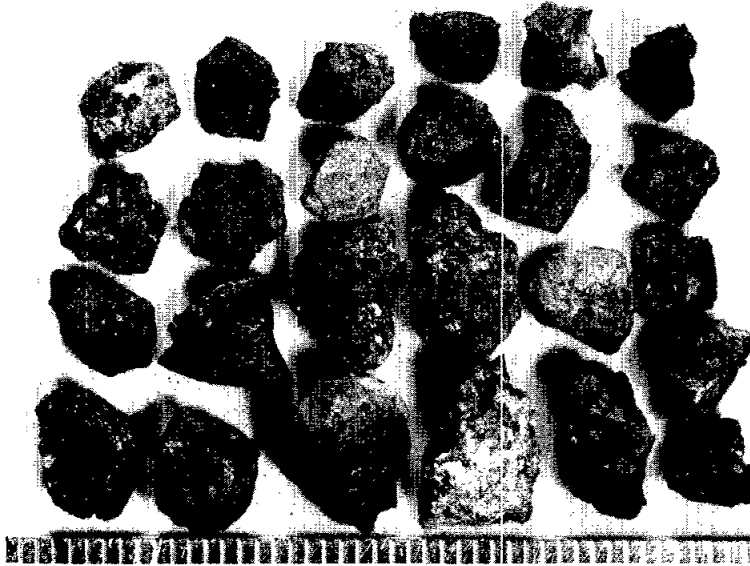

SAMPLE 68504,4

Rock Type: Fine-grained crystallines (4)
Coherence (intergranular): Tough
Shape: Angular, blocky
Surface: Small vesicles present in some grains; others smooth
Color: Light gray to light brown
Special Features: Zap pits common
No. of Particles: 19/ Weight: 6.14g

Remarks: These particles differ from those in sample 68504,3 mainly in color. The two groups would have been combined if sample 68504 were not so rich in fine-grained crystallines.

68504,4

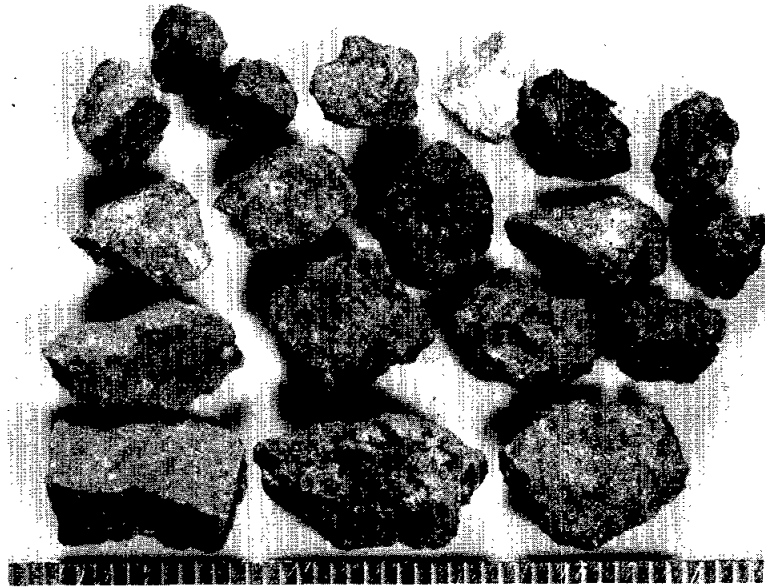

SAMPLE 68504,5

Rock Type: Crystalline anorthosites (5c)
Coherence (intergranular): Friable to coherent
Shape: Subrounded
Surface: Rough, granular
Color: White to light gray
Special Features: None
No. of Particles: 6 / Weight: 1.26g

Remarks: Some of these particles (such as the one at lower right) consist mainly of randomly oriented plagioclase laths; others have equigranular, sugary textures.



SAMPLE 68504,6

Rock Type: Exceptional particles (7)

No. of Particles: 4 / Weight: 1.33g

Remarks: Particle a is an unusually fine specimen of crystalline anorthosite (5c) consisting of a felty intergrowth of plagioclase laths. Small cavities contain euhedral plagioclase crystals.

Particle b is a flattened "pebble" of very fine-grained gray crystalline material (4). It has a somewhat rough surface coated with fine dust. Its rounded shape suggests abrasion, but the particle may be an unusually smooth nodule from an anorthositic breccia.

Particle c is an irregular, somewhat vesicular, light gray crystalline (6a), distinguished by a conspicuous spot of red rust on one surface.

Particle d resembles a geode; it consists mainly of gray aphanitic, almost flinty material with one recessed surface lined with drusy feldspar crystals. In the deepest part of the cavity are several lustrous crystals or globules of brassy troilite.

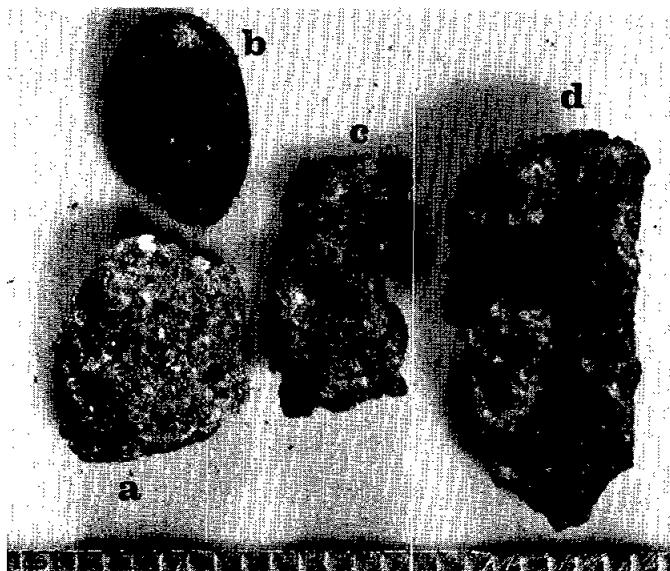

68504,6

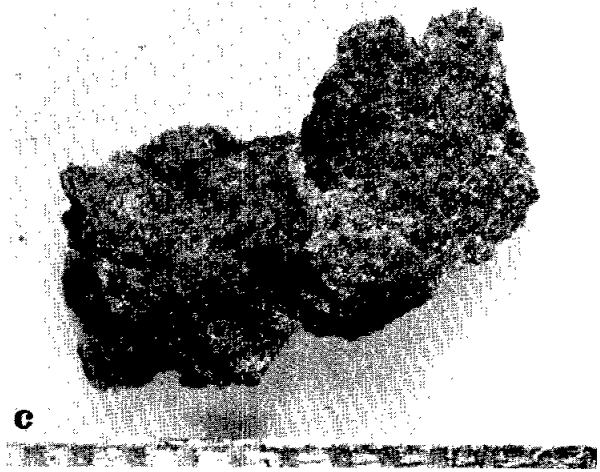
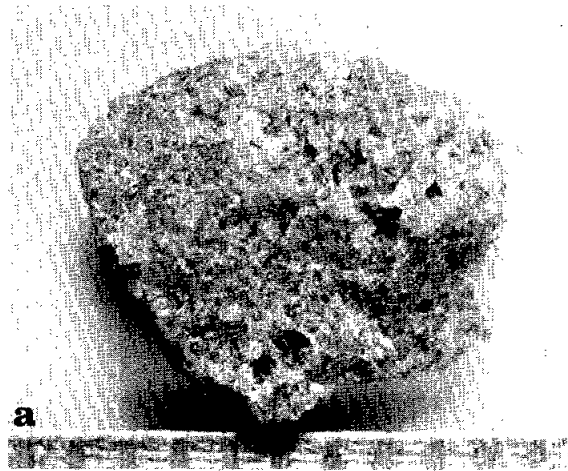

SAMPLE 68124,1 (undusted)

Rock Type: Microbreccias and glass-welded aggregates (1a,1b)
Coherence (intergranular): Friable
Shape: Irregular
Surface: Rough, partially coated with brown cindery glass
Color: Matrixes, light brown; clasts mainly gray and white
Special Features: None
No. of Particles: 6 / Weight: 0.44g

SAMPLE 68124,2 (undusted)

Rock Type: Gray and white microbreccias, (annealed) (3b)
Coherence (intergranular): Friable to coherent
Shape: Blocky to irregular
Surface: Rough; partially coated with glass
Color: Matrixes white; clasts white and gray
Special Features: Large cavities present in one particle
No. of Particles: 5 / Weight: 1.24g

Remarks: The largest of these particles (right) has deep cavities and a smoothly undulating surface; it may be rich in glass.



SAMPLE 68124,3 (undusted)

Rock Type: Glass (2)
Coherence (intergranular): Brittle
Shape: Spherules
Surface: Vitreous; partially coated with fine dust
Color: Dark brown
Special Features: Small pits and blebs on surfaces
No. of Particles: 2 / Weight: 0.28g

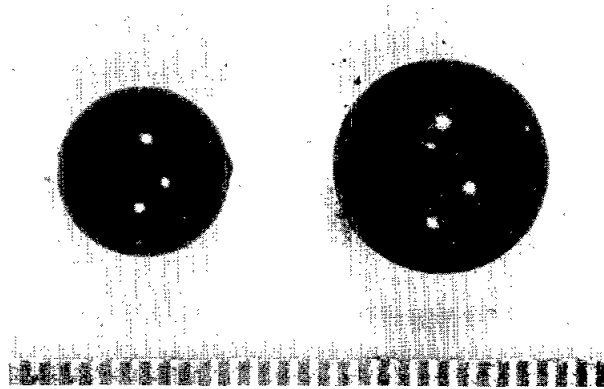

SAMPLE 68124,4 (undusted)

Rock Type: Fine-grained crystallines (4)
Coherence (intergranular): Tough
Shape: Angular; blocky to irregular
Surface: Some fractured surfaces smooth, others rough, vesicular
Color: Various shades of gray
Special Features: Drusy vugs
No. of Particles: .13 / Weight: 4.57g

Remarks: Several of these particles appear to be devitrified glass. Two of them have conspicuous vugs lined with crystals of feldspar and/or metal or sulfide.

68124,4



SAMPLE 68124,5 (undusted)

Rock Type: Glass-rich particles (2)
Coherence (intergranular): Coherent to tough,
Shape: Angular, slabby, with a few rounded vesicles
Surface: Smooth to grainy; partially glass-coated
Color: Gray
Special Features: See Remarks
No. of Particles: 2 / Weight: 0.33g

Remarks: The particle at left is partly vitreous, partly aphanitic. The particle at right is an annealed glass-rich microbreccia that includes a gabbroic clast 7 mm in section. It is cut by two or three non-penetrative fractures.

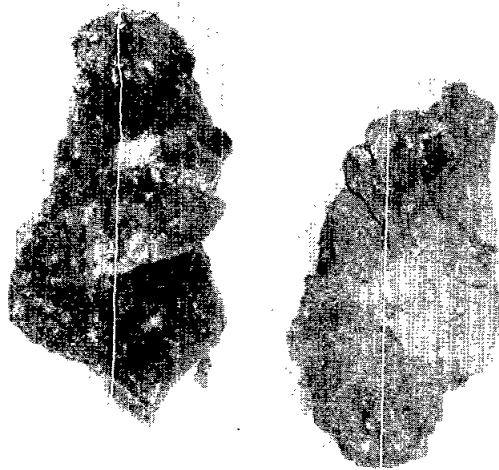

SAMPLE 68124,6 (undusted)

Rock Type: Gray crystallines (6a)
Coherence (intergranular): Friable to coherent
Shape: Angular, blocky
Surface: Rough, granular, with a few small vesicles
Color: Light gray
Special Features: Traces of thin glass crusts; a few zap pits
No. of Particles: 5 / Weight: 0.80g

Remarks: These particles are predominantly plagioclase but appear to have minor mafic silicates and sparse opaques. (Observation uncertain because of dust coat and fine grain size.)

SAMPLE 68124,7 (undusted)

Rock Type: Anorthosites (5a,5c)
Coherence (intergranular): Coherent
Shape: Subangular
Surface: Smooth to granular
Color: White
Special Features: None
No. of Particles: 2 / Weight: 0.51g

Remarks: One particle (left) is a tabular fragment of microbreccia in which colorless fragments occur in an annealed white matrix; the other is a blocky fragment of fine-grained anorthosite with no visible components except plagioclase.

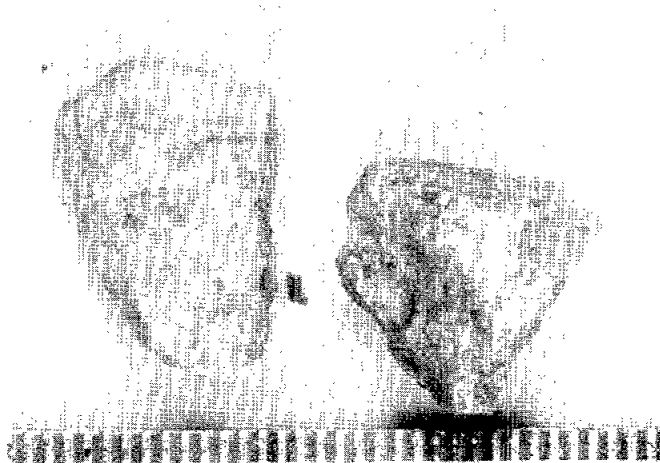

SAMPLE 68844,1

Rock Type: Microbreccias and glass-welded aggregates (1a,1b,1c)
Coherence (intergranular): Friable to coherent
Shape: Subrounded to irregular
Surface: Breccias, grainy; glass, vesicular
Color: Matrixes light brown to gray; glass brown, cindery
Special Features: None
No. of Particles: 13/ Weight: 1.56g

Remarks: Four of these microbreccias are partially annealed
and more coherent than the rest.

SAMPLE 68844,2

Rock Type: Aphanitic crystallines (4)
Coherence (intergranular): Tough, flinty
Shape: Irregular
Surface: Abundant vesicles and rounded cavities
Color: Gray to light brown
Special Features: Zap pits on some surfaces
No. of Particles: 10/ Weight: 2.21g

Remarks: Particles are probably recrystallized glasses.

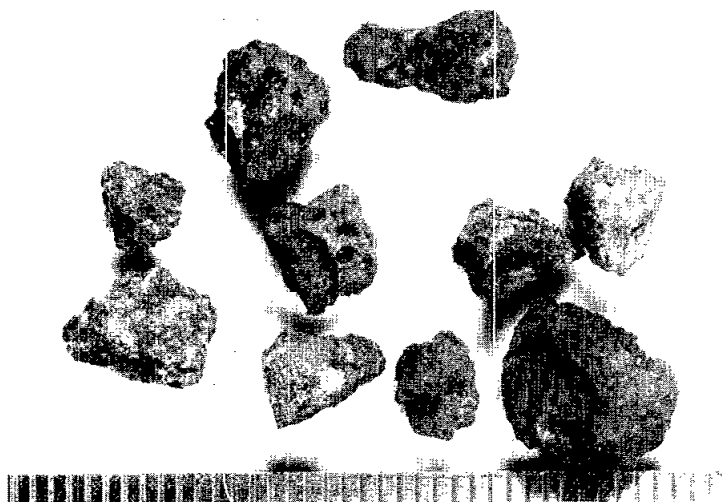

SAMPLE 68844,3

Rock Type: Anorthosites; fine-grained crystalline (5c)
Coherence (intergranular): Tough, competent
Shape: Angular
Surface: Granular; partly coated with dust
Color: Light gray to white
Special Features: Sparse zap pits
No. of Particles: 6 / Weight: 0.66g

SAMPLE 68844,4

Rock Type: Exceptional particles (7)
Coherence (intergranular): Tough
Shape: Blocky
Surface: Rough; with cavities
Color: Light gray
Special Features: See Remarks
No. of Particles: 2 / Weight: 0.28g

Remarks: These two particles are exceptional for the contents of their cavities. The particle at left has a small round cavity filled with a clump of metallic globules which resembles, on a mini-scale, the large globular aggregate of particle 63344,1. The particle at right has a deep irregular cavity partially lined with metal or sulfide crystals.



SAMPLE 68824,1

Rock Type: Anorthositic microbreccia (5a)
Coherence (intergranular): Very friable
Shape: Subrounded
Surface: Rough, with several small cavities
Color: White
Special Features: A crust and several droplets of black glass
No. of Particles: 1 / Weight: 0.16g

Remarks: Numerous tiny spots of orange rust occur around cavities and on fractured surfaces.

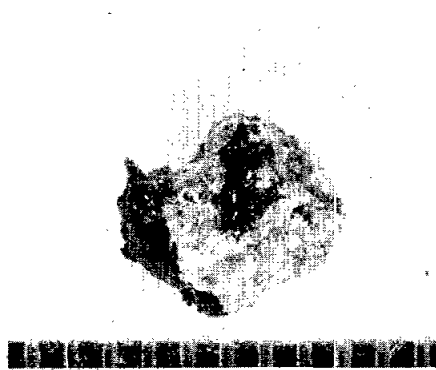

SAMPLE 68824,2

Rock Type: Glassy particles (2)
Coherence (intergranular): Brittle
Shape: Irregular
Surface: Vesicular
Color: Dark gray; vitreous to aphanitic
Special Features: Sparse zap pits
No. of Particles: 3 / Weight: 0.41g

Remarks: Particles are devitrified or recrystallized glass with white crushed anorthosite adhering to some surfaces.

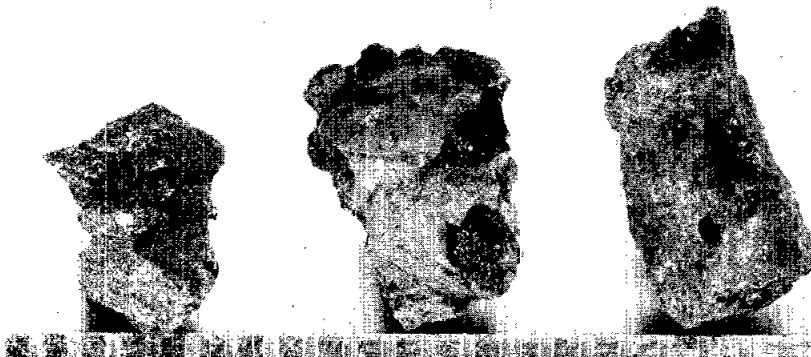

SAMPLE 68824,3

Rock Type: Annealed gray and white microbreccias (3b)
Coherence (intergranular): Tough
Shape: Irregular
Surface: Rough, with small irregular voids and round vesicles
Color: Gray mottled with white
Special Features: Sparse zap pits
No. of Particles: 3 / Weight: 0.59g

Remarks: These particles have white relict clasts in a gray groundmass and a rough, vesicular form. They are probably strongly annealed breccias rich in glass.

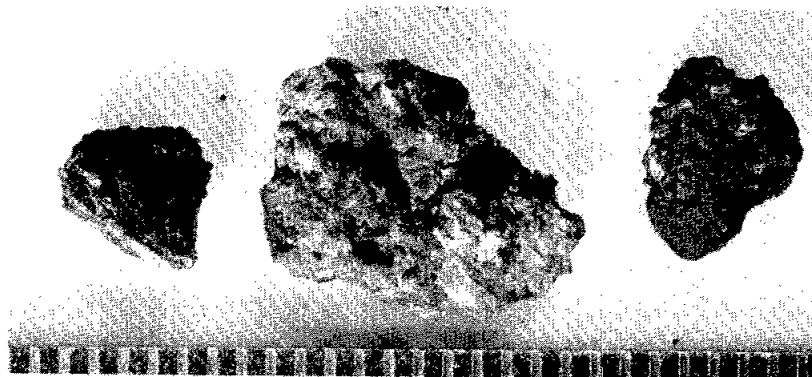

SAMPLE 68824,4

Rock Type: Exceptional particle (7)
Coherence (intergranular): Coherent
Shape: Angular; with imposed parting planes
Surface: One surface smooth, polished
Color: Light gray; aphanitic
Special Features: Zap pits abundant on polished surface
No. of Particles: 1 / Weight: 0.12g

Remarks: The exceptional aspect of this particle is its single polished surface which shows faint but distinct unidirectional grooving. It has clearly been polished by abrasion.

SAMPLE 68824,5

Rock Type: Anorthosite (5c)
Coherence (intergranular): Friable; crystals easily dislodged
Shape: Rounded
Surface: Partially coated with patches of brownish glass
Color: Gray-white
Special Features: Sparse zap pits
No. of Particles: 1 / Weight: 0.18g

Remarks: The particle as a whole is light gray and very fine-grained; tiny laths of white plagioclase and grains of metal are the only visible components.



68824,4



68824,5

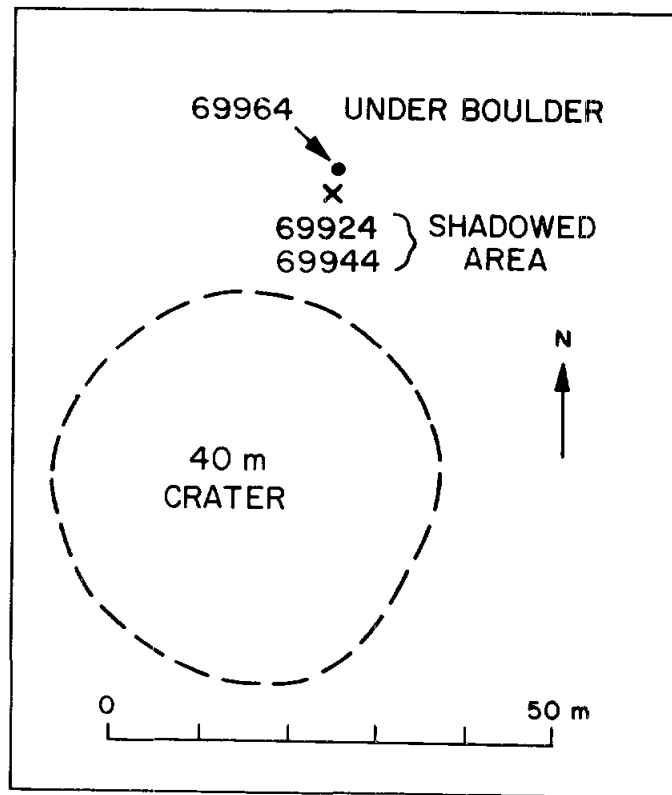

STATION 9

Station 9 is about 400 m north of Station 8 at a site strewn with both light and dark ejecta from South Ray Crater. The three samples of coarse fines in this collection were taken close to an angular 0.5 m boulder on the rim of a crater about 40 m in diameter. Sample 69924 is from surface soil skimmed from the shadow of the boulder; sample 69944 is from a scoop sample also taken in the shadow of the boulder. After they had finished sampling the boulder itself and the nearby soils, the astronauts rolled the boulder aside and collected sample 69964 from beneath it.

SAMPLE 69924,1

Rock Type: Microbreccias, and a glass-welded aggregate (1a,1b)
Coherence (intergranular): Friable
Shape: Angular
Surface: Rough
Color: Matrixes light brown; clasts light and dark; glass brown
Special Features: None
No. of Particles: 9 / Weight: 0.41g

SAMPLE 69924,2

Rock Type: Gray and white microbreccia (3a)
Coherence (intergranular): Friable
Shape: Angular
Surface: Very rough and jagged
Color: White matrix with gray angular clasts
Special Features: Glass-lined zap pits
No. of Particles: 1 / Weight: 0.19g

Remarks: Several conspicuous spots of red rust occur on
particle.

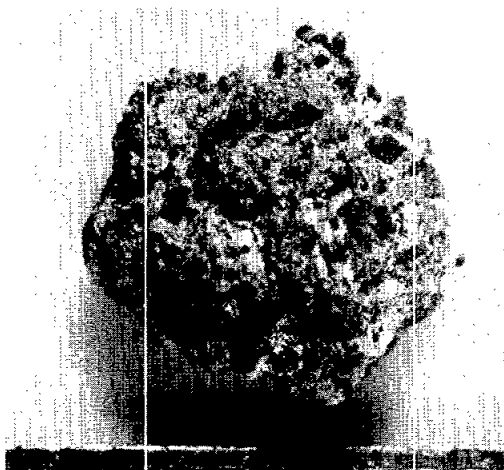

SAMPLE 69924,3

Rock Type: Glassy particle (2)
Coherence (intergranular): Tough
Shape: Very irregular
Surface: Vesicular; vitreous to aphanitic
Color: Dark gray, translucent to opaque
Special Features: White recrystallized clasts visible
No. of Particles: 1 / Weight: 0.08g

Remarks: Tiny metal or sulfide globules visible on fractured surfaces.



SAMPLE 69924,4

Rock Type: Anorthosite, fine-grained crystalline (5c)
Coherence (intergranular): Tough
Shape: Rounded
Surface: Rough, sugary; with tiny voids
Color: Light gray
Special Features: Several glass-lined zap pits
No. of Particles: 1 / Weight: 0.15g



SAMPLE 69924,5

Rock Type: Very fine-grained crystallines (4)
Coherence (intergranular): Coherent except for one deep fracture
Shape: Angular
Surface: Irregular
Color: Mottled gray and white
Special Features: Patches of light brown glass on surfaces
No. of Particles: 2 / Weight: 0.15g

Remarks: Particles are probably recrystallized anorthositic breccias.

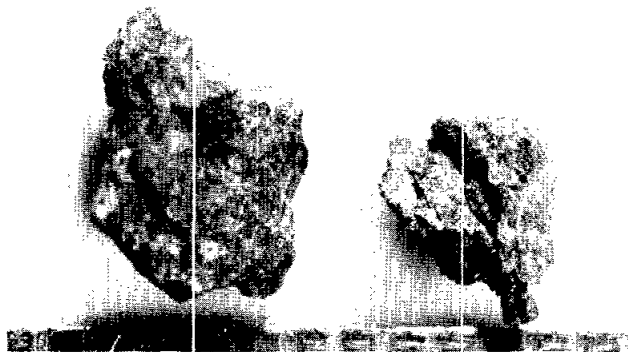

SAMPLE 69944,1

Rock Type: Microbreccias and glass-welded aggregates (1a,1b,1c)
Coherence (intergranular): Very friable to tough
Shape: Rounded to angular
Surface: Partially coated with brown cindery glass
Color: Matrixes gray to brown; clasts gray and white
Special Features: None
No. of Particles: 5 / Weight: 0.41g

Remarks: The two breccias at right are cohesive soils; very friable and rounded by abrasion; the two at left are coated or welded by brown, cindery glass; the breccia at center is annealed and tough with a black matrix, white clasts, and a partial coating of dark glass.



SAMPLE 69944,2

Rock Type: Gray and white microbreccias (3a)
Coherence (intergranular): Friable to coherent
Shape: Angular
Surface: Partially soil-covered
Color: Matrixes white; clasts and lenses gray
Special Features: None
No. of Particles: 3 / Weight: 0.40g

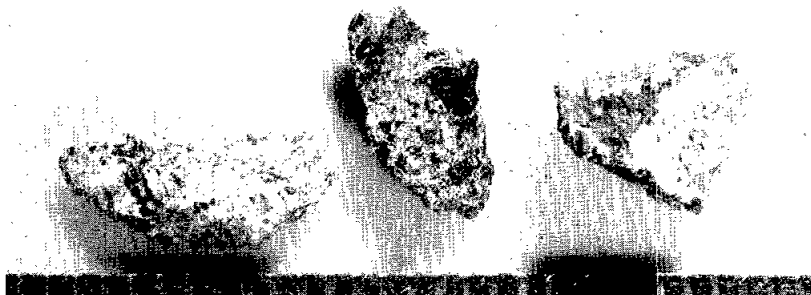

SAMPLE 69944,3

Rock Type: Glasses (2)

Coherence (intergranular): Brittle, with conchoidal fracture

Shape: Spherules and angular chunks

Surface: Chunks are vesicular

Color: Dark brown, green, and gray; vitreous to aphanitic

Special Features: Zap pits on several particles

No. of Particles: 11/ Weight: 1.63g

Remarks: Of the four spherules in this sample, a and b are severely chipped as a result of zap pitting, c is coated with rough soil particles, and d is flattened and has a large saucer-shaped depression in one side. The bottom of the depression preserves a rounded mold as though impacted by a spherule while the glass was still warm. Spherule d is dented but not fractured.

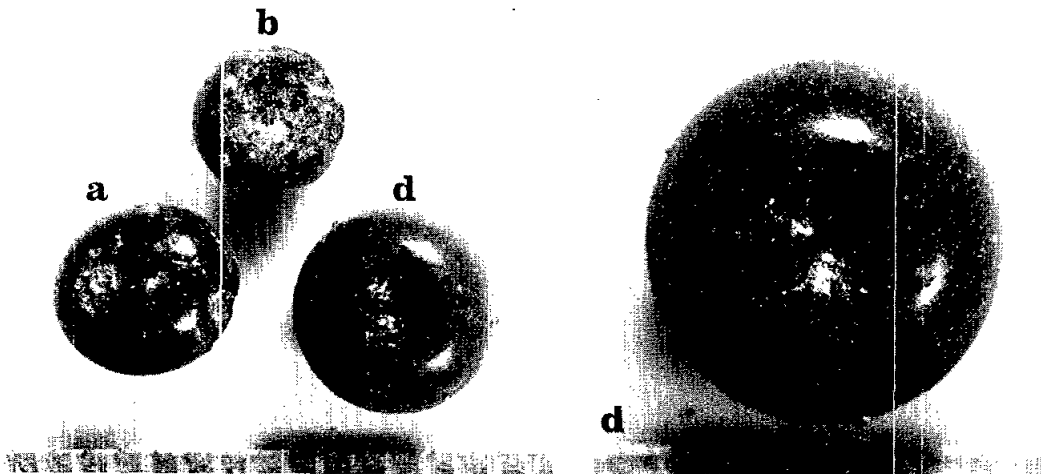
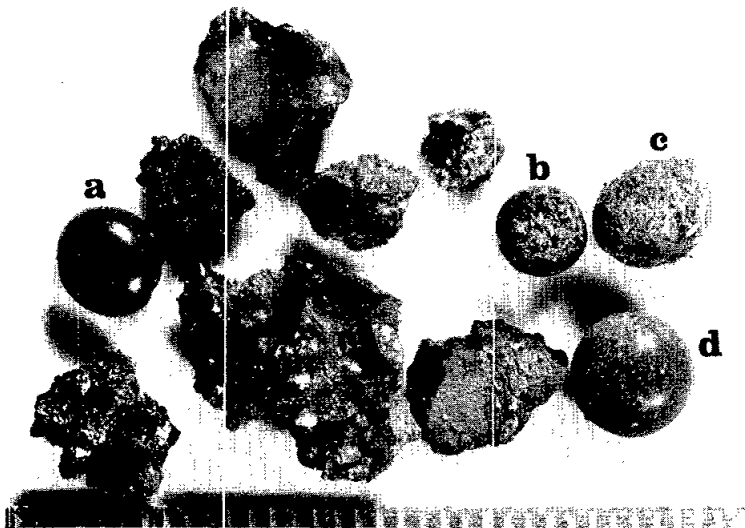

SAMPLE 69944,4

Rock Type: Fine-grained crystallines (4)
Coherence (intergranular): Tough
Shape: Angular, blocky
Surface: Somewhat vesicular; fractured surfaces smooth
Color: Dark to light gray
Special Features: None
No. of Particles: 6 / Weight: 1.03g

SAMPLE 69944,5

Rock Type: Anorthosite (5c)
Coherence (intergranular): Tough
Shape: Blocky
Surface: Sugary
Color: White
Special Features: 3 droplets of light green glass on one surface
No. of Particles: 1 / Weight: 0.12g

Remarks: The droplets on this fragment are the only light green glasses observed in the 4-10 mm fines. They are reminiscent of the apple green glasses that were abundant in the Apollo 15 samples, but are of a grayer, more subdued color.

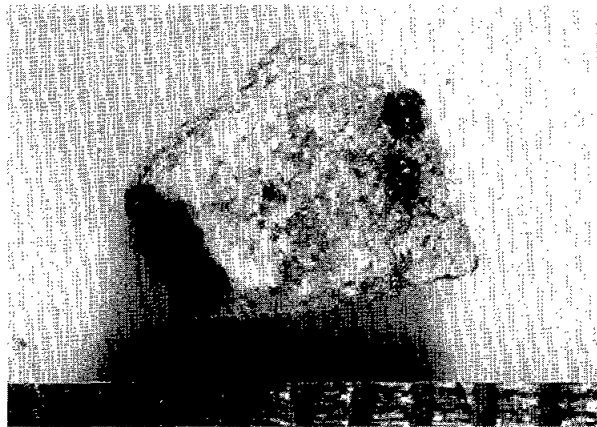

SAMPLE 69944,6

Rock Type: Gray and white microbreccias; annealed (3b)
Coherence (intergranular): Coherent
Shape: Angular to subrounded
Surface: Finely granular, partially glass-coated
Color: Gray mottled with white
Special Features: See Remarks
No. of Particles: 2 / Weight: 0.43g

Remarks: The smaller particle shows a faint suggestion of a banded texture.



SAMPLE 69964,1

Rock Type: Glass-rich particles (2)
Coherence (intergranular): Brittle
Shape: Very irregular
Surface: Vesicular
Color: Dark brown
Special Features: One particle includes a large clast of gray microbreccia
No. of Particles: 2 / Weight: 0.53g

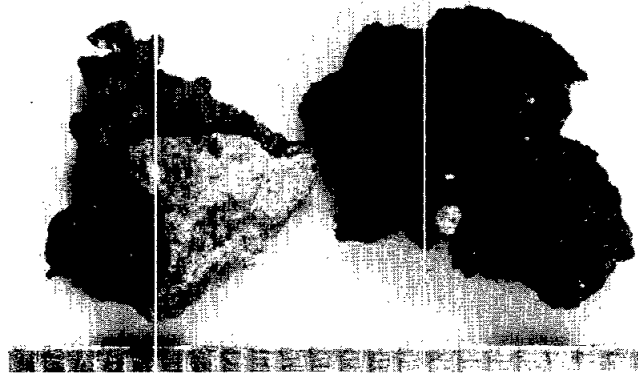

SAMPLE 69964,2

Rock Type: Anorthosites (5c)
Coherence (intergranular): Coherent
Shape: Angular
Surface: Smooth to granular; partially soil-coated
Color: White to gray
Special Features: See Remarks
No. of Particles: 2 / Weight: 0.70

Remarks: The larger particle actually consists of two rock types: a sugary white crystalline anorthosite attached to a gray and white annealed microbreccia. The particle is largely coated with brown soil.

The elongate particle is of white, translucent plagioclase studded at one end with crystals of brown pyroxene (?)



SAMPLE 69964,3

Rock Type: Microbreccias (1a,1c)
Coherence (intergranular): 2 particles friable; one tough, annealed
Shape: Rounded
Surface: Grainy; partly coated with brown cindery glass
Color: Friable matrixes gray; annealed matrix black
Special Features: None
No. of Particles: 3 / Weight: 0.37g

Remarks: The annealed particle includes angular white and yellow clasts.

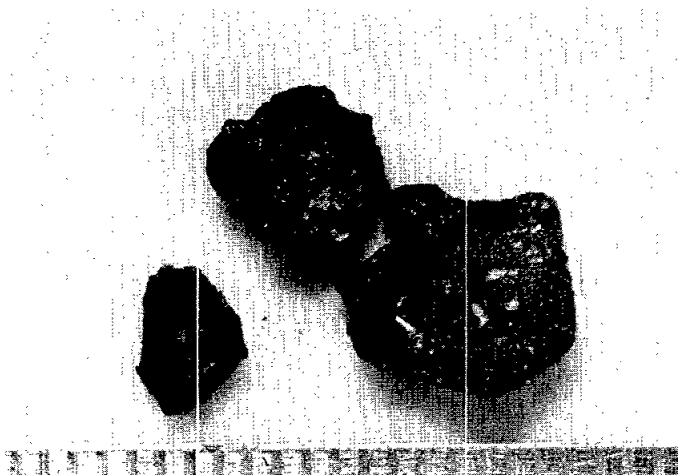

SAMPLE 69964,4

Rock Type: Fine-grained crystallines (4)
Coherence (intergranular): Tough
Shape: Angular, blocky
Surface: Smooth to roughly granular
Color: Gray to light brown
Special Features: None
No. of Particles: 5 / Weight: 1.02g

69964,4

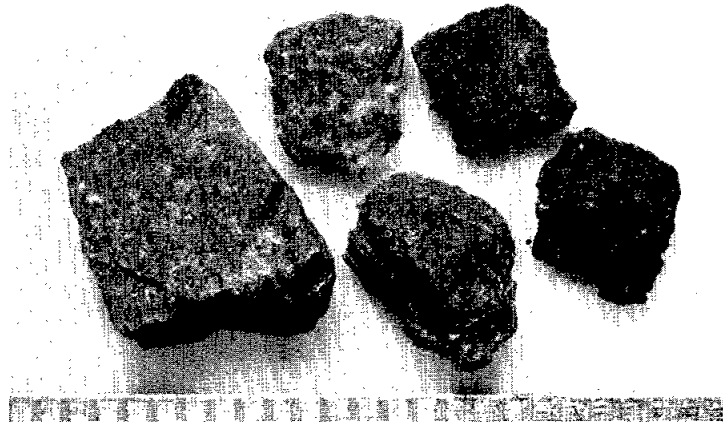

SAMPLE 69964,5

Rock Type: Aphanitic particles; glass-rich (?) (2)
Coherence (intergranular): Tough
Shape: Angular, slabby
Surface: Pitted with vesicles up to 3 mm in diameter
Color: Dark gray
Special Features: None
No. of Particles: 4 / Weight: 0.98g

Remarks: These particles are aphanitic, almost flinty in character. They are probably devitrified glasses.



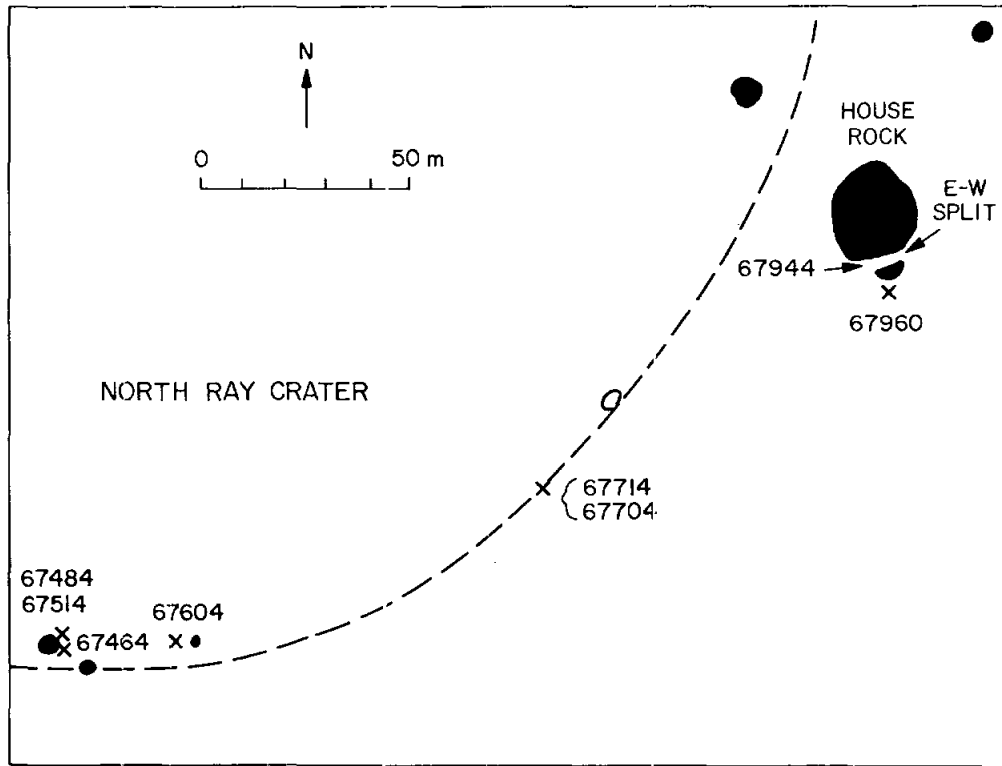

STATION II

Stations 11 and 13 are the only two sampling sites that lie north of the LM. Station 11 is on the SE rim of North Ray Crater. The immense block of crater ejecta called House Rock lies about 20 m outside the rim crest. House Rock and other large boulders are represented by black dots and patches in the figure above. The regolith in this general vicinity proved to be unexpectedly thin. Except for fillets around rounded boulders, the soils are only a few cm thick. Samples from the crater rim include 67704 from a white patch on the regolith, and 67414 from a rake sample area at the same general site. Farther south along the rim, sample 67484 was taken as a reference soil and 67514 and 67604 are from rake sample sites. Sample 67464 is from a fillet around a white breccia boulder. Sample 67944 is from the E-W split in House Rock, which is a breccia consisting of white clasts in a dark matrix.

SAMPLE 67704,1

Rock Type: Glassy particles (2)
Coherence (intergranular): Brittle
Shape: Irregular
Surface: Vesicular; with attached soil and microbreccia
Color: Gray to brown; aphanitic
Special Features: Zap pits on some surfaces
No. of Particles: 2 / Weight: 0.29g

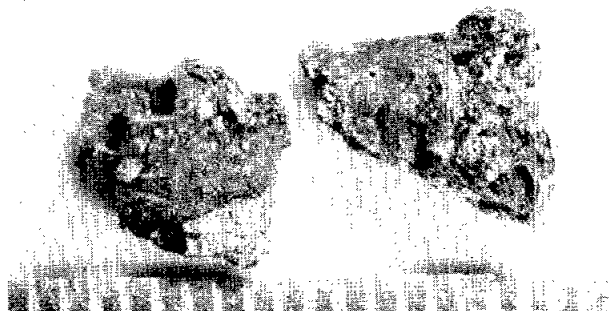

SAMPLE 67704,2

Rock Type: Gray and white microbreccias (3a,3b)
Coherence (intergranular): Friable to cohesive
Shape: Angular to subrounded
Surface: Very rough and irregular
Color: Matrixes chalky white; clasts angular, gray and white
Special Features: Glass coating some surfaces
No. of Particles: 14/ Weight: 2.17g

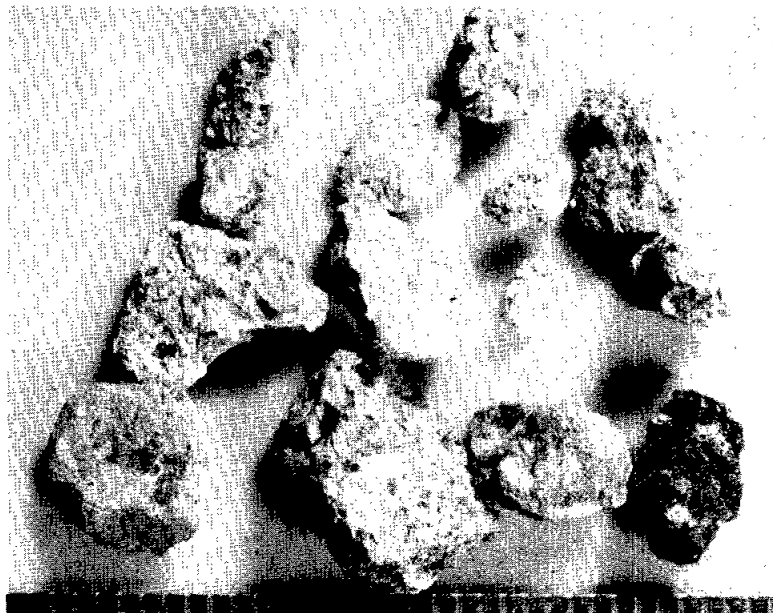

SAMPLE 67704,3

Rock Type: Fine-grained crystallines (4)
Coherence (intergranular): Tough
Shape: Angular, blocky
Surface: Most particles fairly smooth; two or three vesicular
Color: Various shades of gray
Special Features: None
No. of Particles: 15/ Weight: 1.98g

SAMPLE 67704,4

Rock Type: Anorthosite (5c)
Coherence (intergranular): Coherent
Shape: Subrounded
Surface: Granular; partially coated with white powdery dust
Color: Pure white
Special Features: None
No. of Particles: 1 / Weight: 0.14g

SAMPLE 67714,1

Rock Type: Microbreccias (1a)
Coherence (intergranular): Very friable
Shape: Angular to subangular
Surface: Grainy
Color: Matrixes gray; clasts gray and white
Special Features: None
No. of Particles: 5 / Weight: 0.26g



SAMPLE 67714,2

Rock Type: Gray and white annealed microbreccias (3b)
Coherence (intergranular): Coherent
Shape: Angular to subrounded
Surface: Rough; partly coated with white powdery soil
Color: Matrixes white; clasts gray and white
Special Features: Spot of red rust on one particle
No. of Particles: 8 / Weight: 1.07g

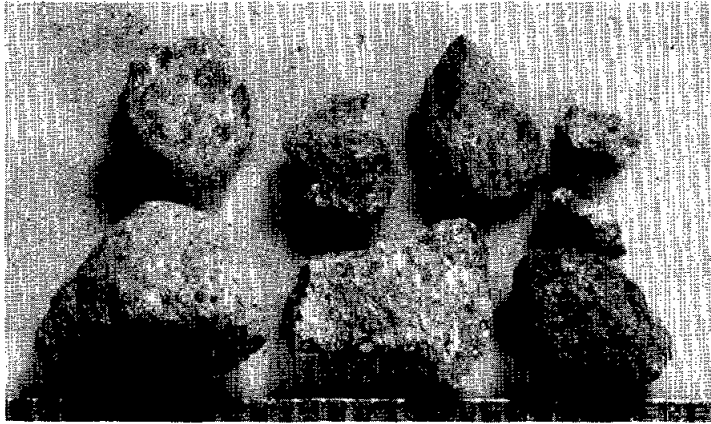

SAMPLE 67714,3

Rock Type: Anorthosites (5c)
Coherence (intergranular): Rough; minor fracturing in one particle
Shape: Subangular
Surface: Sugary
Color: White to very light gray
Special Features: None
No. of Particles: 6 / Weight: 0.81g

Remarks: Three particles are white with a sugary, equigranular texture; 3 are grayish with similar texture.



SAMPLE 67714,4

Rock Type: Recrystallized microbreccias (3b)
Coherence (intergranular): Tough
Shape: Angular; a few non-penetrative fractures
Surface: Very fine grained; partly coated with white dust
Color: Gray, mottled with white relict clasts
Special Features: None
No. of Particles: 11/ Weight: 3.38g

Remarks: On freshly fractured surfaces the gray rock is webbed with light streaks indicative of the original clastic nature of the material.



SAMPLE 67714,5

Rock Type: Fine-grained crystallines (4)
Coherence (intergranular): Tough
Shape: Angular to subrounded
Surface: Most are smooth; a few, very rough
Color: Various shades of gray
Special Features: See remarks
No. of Particles: 21/ Weight: 5.44g

Remarks: Two of these particles are dark gray, rough-surfaced, riddled with tiny vesicles and have numerous zap pits. They are apparently devitrified glasses. The remaining 19 particles are very fine-grained, have smooth surfaces partially covered with fine white dust and are typical clasts from gray and white microbreccias.



SAMPLE 67484,1

Rock Type: Glassy particles (2)
No. of particles: 8/ Weight: 1.14g

Remarks: These particles include the following 3 types:

- a. Thin, rather fragile wafery crusts of vesicular glass, colorless to light brown, liberally coated with fine soil and detritus. (3 particles)
- b. Irregular masses of vitreous to aphanitic, brown cindery glass; the largest particle includes two fragments of light-colored crystalline rock. (3 particles)
- c. Vesicular glass devitrified to a gray, opaque variety. (2 particles)

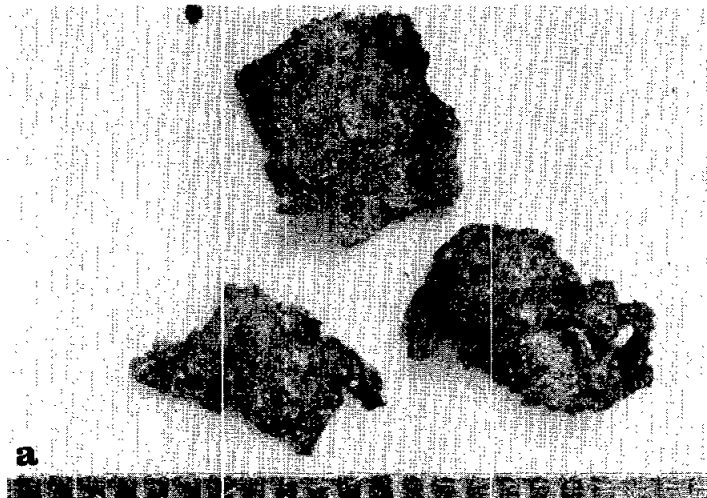
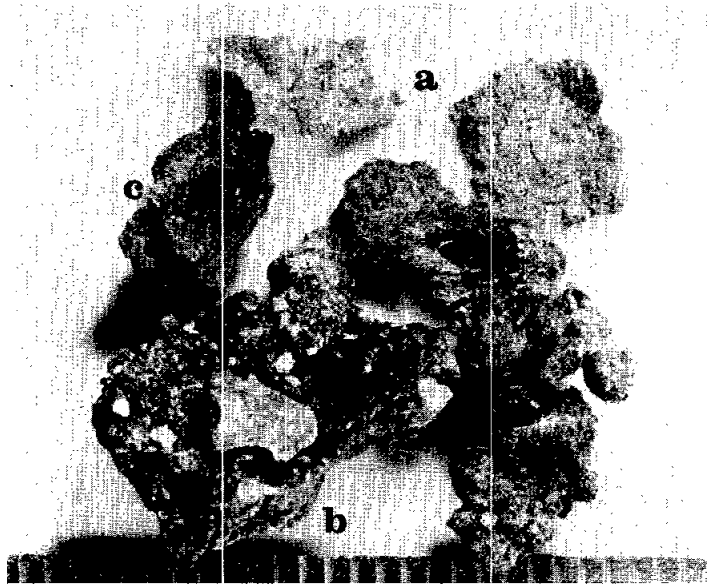

SAMPLE 67484,2

Rock Type: Fine-grained crystallines (4)
Coherence (intergranular): Tough
Shape: Angular
Surface: Relatively smooth
Color: Light to medium gray
Special Features: None
No. of Particles: 9 / Weight: 1.48g

SAMPLE 67484,3

Rock Type: Anorthositic microbreccias (5a)
Coherence (intergranular): Friable and shedding fragments
Shape: Rounded
Surface: Smooth to rough and irregular
Color: Chalky white to light gray; one particle coated with brown dust
Special Features: None
No. of Particles: 7 / Weight: 0.54g

Remarks: Five of these particles consist mainly of white fragments in a floury white matrix; one is gray and white; one is irregular, dust-coated, and may be partially glass.



SAMPLE 67484,4

Rock Type: Crystalline anorthosites (5b, 5c)
Coherence (intergranular): Coherent
Shape: Angular
Surface: Pitted with a few small vuggy cavities
Color: White to light gray and white
Special Features: Glass-lined zap pits present
No. of Particles: 4 / Weight: 0.95g

Remarks: Particle a is chalky white with sparse dark aphanitic inclusions (5b); the other three particles are crystalline anorthosites (5c).

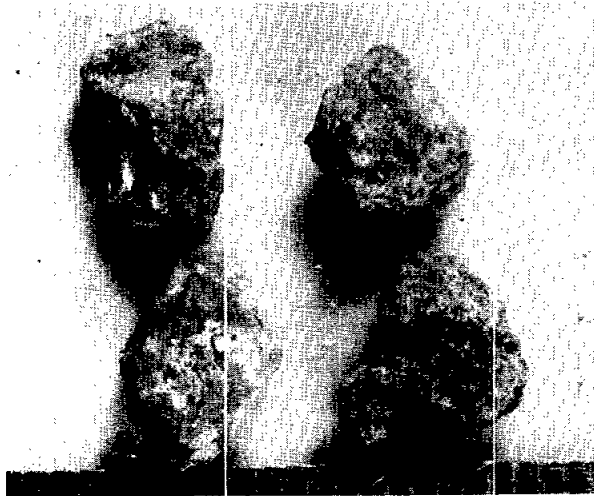

SAMPLE 67514,1

Rock Type: Gray and white microbreccias (3a)
Coherence (intergranular): Friable
Shape: Subrounded
Surface: Rounded vesicles common; glassy crusts rare
Color: Matrixes white; clasts white or gray, aphanitic
Special Features: None
No. of Particles: 60/ Weight: 15.17g

Remarks: These breccias range from nearly pure white to medium gray; they could probably equally well be classed as anorthositic breccias, category 5a.



SAMPLE 67514,2

Rock Type: Anorthosites (5a)
Coherence (intergranular): Friable to coherent
Shape: Angular
Surface: Rough
Color: Chalky white; sparse gray veinlets and inclusions
Special Features: Rare zap pits lined with colorless glass
No. of Particles: 13/ Weight: 3.32g

Remarks: These particles are of substantially the same composition as the matrix materials of 67514,1; but are of extraordinary purity.

67514,2

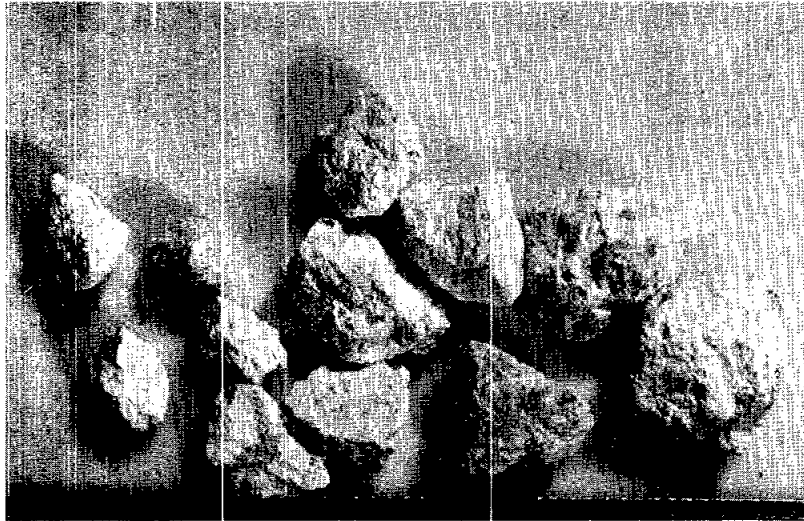

SAMPLE 67514,3

Rock Type: Fine-grained crystallines (4)
Coherence (intergranular): Tough
Shape: Angular
Surface: Aphanitic and smooth to fine-grained and rough
Color: Dark gray
Special Features: Most grains coated with fine white dust
No. of Particles: 1.0/ Weight: 2.63g

Remarks: These chunks are probably disaggregated gray clasts from white breccias of the type in 67514,1.

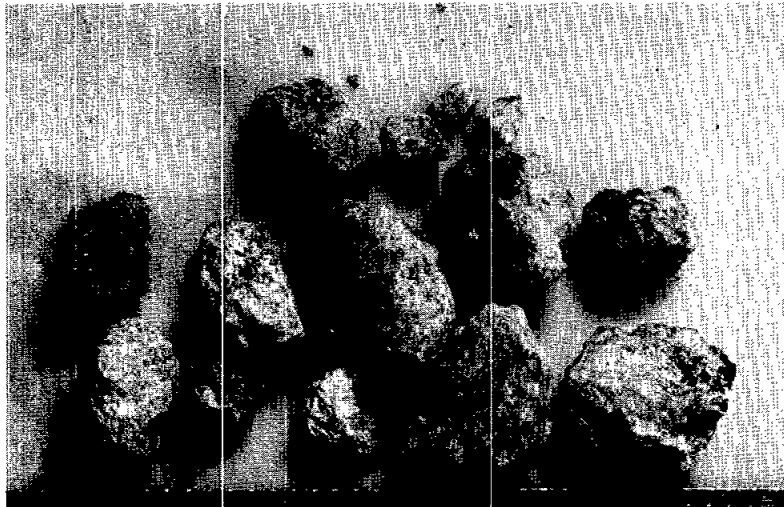

SAMPLE 67514,4

Rock Type: Anorthosites (shocked) (5b,5c)
Coherence (intergranular): Friable to coherent
Shape: Angular
Surface: Rough; granular
Color: Chalky white with dark angular inclusions
Special Features: Rust spots on some gray patches
No. of Particles: 14/ Weight: 2.63g

Remarks: These particles appear to be shocked in situ with plagioclase made chalky white and mafics granulated or aphanitic. Some dark inclusions are rhombic in section. Macroscopically the particles do not appear to be polymict breccias; a few have textures that are regular enough to resemble graphic granite. One particle (far left) is unusual in having a mass of honey-yellow pyroxene as a mafic phase.

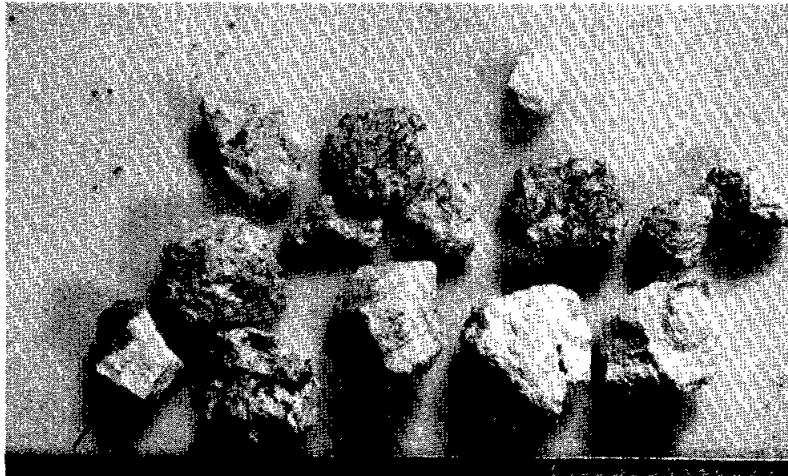

SAMPLE 67514,5

Rock Type: Gabbroic anorthosite (5d)
Coherence (intergranular): Coherent
Shape: A subangular chip
Surface: Rough, granular
Color: White
Special Features: None
No. of Particles: 1 / Weight: 0.15g

Remarks: This particle has a granulitic texture with white to colorless plagioclase predominating; yellow mafic minerals minor, and sulfide crystals present as accessories.



SAMPLE 67514,6

Rock Type: Anorthosite (5c)
Coherence (intergranular): Tough
Shape: Angular
Surface: Nearly smooth on fresh fractures
Color: Light gray
Special Features: None
No. of Particles: 1 / Weight: 0.09g

Remarks: A very fine-grained crystalline rock predominantly of plagioclase with tiny grains of metal or sulfide.

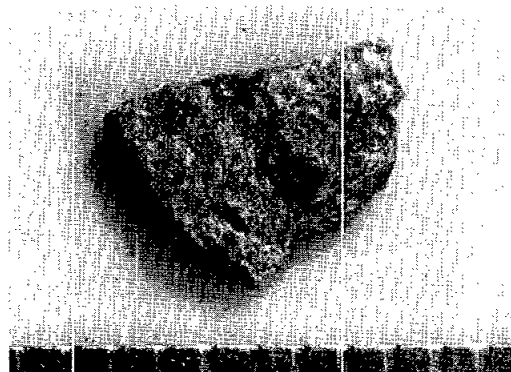

SAMPLE 67464,1

Rock Type: Glassy particles (2)
No. of Particles: 2/ Weight: 0.15g

Remarks: Two particles: (Left) a flattened, irregular, twisted mass of ropy glass with adhering grains of soil and fine dust.
(Right) a dark gray aphanitic fragment with one smoothly curving flow surface indented by a rounded vesicle and one zap pit; the other surfaces are irregular and partly coated with fine white soil and anorthositic microbreccia.

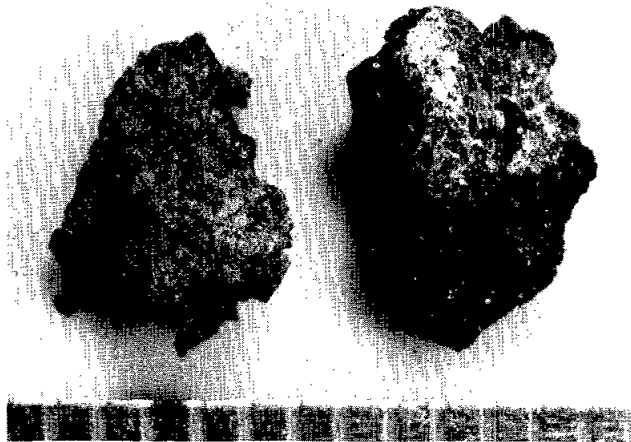

SAMPLE 67464,2

Rock Type: Gray and white microbreccias; annealed (3b)
Coherence (intergranular): Coherent; one penetrative fracture
Shape: Angular to subangular
Surface: Smooth
Color: Matrixes white mottled with gray
Special Features: See Remarks
No. of Particles: 2 / Weight: 0.23g

Remarks: Fine-grained white crystallines laced with gray.
The particle at right has a "crust" 1 mm thick
of gray aphanitic material.



SAMPLE 67464,3

Rock Type: Fine-grained crystalline (4)
Coherence (intergranular): Tough
Shape: Angular
Surface: Rough
Color: Light gray
Special Features: A few tiny vesicles
No. of Particles: 1 / Weight: 0.10g

Remarks: Sparse grains of metal or sulfide visible.

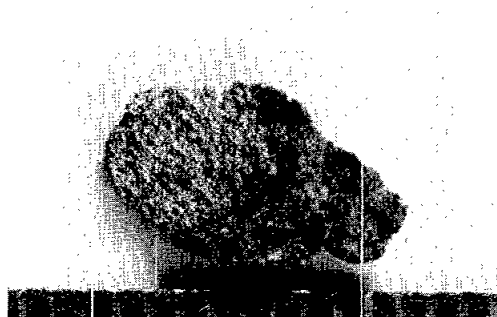

SAMPLE 67464,4

Rock Type: Microbreccia, (3b) (recrystallized)
Coherence (intergranular): Coherent
Shape: Angular
Surface: Irregularly chipped
Color: Dark gray webbed with white streaks and lenses
Special Features: None
No. of Particles: 1 / Weight: 0.17g

Remarks: This particle is so aphanitic it resembles
chalcedony. It is a recrystallized cataclastic
breccia with one prominent white veinlet.



SAMPLE 67604,1

Rock Type: Anorthositic crystallines (5c)
Coherence (intergranular): Coherent
Shape: Subrounded
Surface: Irregular, with small vugs and rounded vesicles
Color: Light gray to white
Special Features: Zap pits present
No. of Particles: 4 / Weight: 1.62g

Remarks: Textures vary from very fine to fairly coarse-
grained; light, irregular patches appear to be
relict clasts in recrystallized anorthositic breccias.

67604,1



SAMPLE 67604,2

Rock Type: Gray and white microbreccias (3a)
Coherence (intergranular): Friable
Shape: Angular
Surface: Very irregular
Color: Chalky white matrixes with gray and white angular clasts
Special Features: Zap pits present
No. of Particles: 3 / Weight: 0.94g

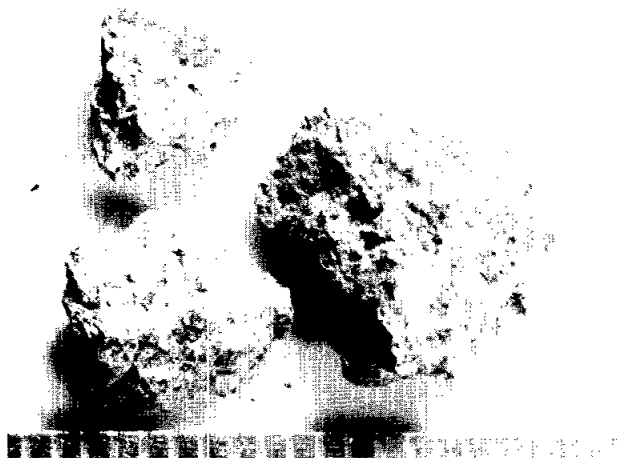

SAMPLE 67944,1

Rock Type: Fine-grained crystallines (4)
Coherence (intergranular): Coherent
Shape: Angular, blocky
Surface: Rough with small rounded vesicles
Color: Ranges from light to dark gray and light brown
Special Features: Zap pits common on some surfaces
No. of Particles: 13/ Weight: 4.65g

Remarks: Most of these particles may be devitrified glasses.
Particle a, 17 mm long, has one smooth, concave
surface with semi-vitreous luster showing a felty
intergrowth of lath-like crystals. Adhering to
the surface are two globular masses of brassy
sulfide, one of which is dented by a zap pit.
Zap pits are also common on the rest of the
surface.



SAMPLE 67944,2

Rock Type: Mottled gray crystallines (6b)
Coherence (intergranular): Friable; shedding small chips
Shape: Angular, slabby
Surface: Rough, granular
Color: Gray, mottled and streaked with white
Special Features: None
No. of Particles: 8 / Weight: 2.06g

Remarks: These rocks have light streaks and patches in a gray groundmass which suggests that they are recrystallized gray and white breccias. On a finer scale they have a "salt-and-pepper" look similar to that of very fine-grained granites. However, if any dark mineral is present, it is in grains too minute to be visible under a binocular microscope. Some of the particles have delicate veins of dark glass.



SAMPLE 67944,3

Rock Type: Glassy veins (2) in anorthositic microbreccias (5a)
Coherence (intergranular): Coherent
Shape: Tabular
Surface: Smooth
Color: Black glass; white breccia
Special Features: See Remarks
No. of Particles: 2 / Weight: 0.66g

Remarks: One vein of black glass has abundant white
aphanitic inclusions; the other is wholly black;
vitreous in the center and aphanitic along both
chilled margins.



SAMPLE 67944,4

Rock Type: Microbreccias: gray and white (3b); anorthositic (5a)

No. of Particles: 2 / Weight: 0.67g

Remarks: These two particles are classed together because they are the only microbreccias in sample 67944. The large gray and white breccia is annealed, coherent, angular, and has a few prominent zap pits on its surface. The small white particle is a friable anorthositic breccia.



SAMPLE 67944,5

Rock Type: Gabbroic anorthosite (5d)

Coherence (intergranular): Coherent

Shape: Subangular

Surface: Rough, sugary

Color: One particle yellowish brown; one gray

Special Features: None

No. of Particles: 2 / Weight: 0.30g

Remarks: These particles appear to consist of white plagioclase (60%) honey-yellow mafics (40%) sparse fine-grained black opaques and rare grains of sulfide.

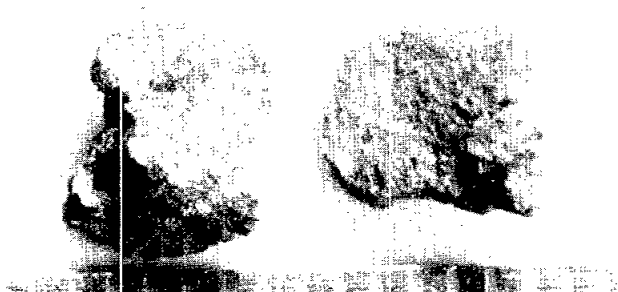

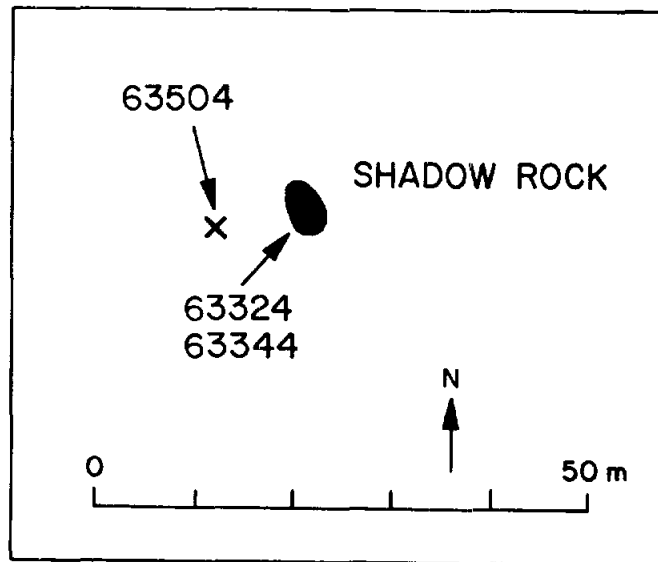

STATION 13

Station 13 is about 0.5 km SE of the rim of North Ray Crater on a thick deposit of ejecta. The most striking feature at the site is Shadow Rock, a jagged block of breccia about 3 m high and 4 m wide. Shadow Rock which consists of white clasts in a black, vesicular matrix is presumably a block of ejecta from North Ray crater. One end of the rock projects out over the surface of the soil and not only casts a shadow but also shields a small area from primary or secondary impacts. Soil samples from this area, including 63324 and 63344, represent North Ray crater ejecta that has been undisturbed since Shadow Rock was emplaced; sample 63504, in contrast, is from a rake sample site about 8 m to the east where the regolith has been subject to gardening.

SAMPLE 63504,1

Rock Type: Gray and white microbreccias (3a,3b)
Coherence (intergranular): Friable to coherent
Shape: Angular to rounded
Surface: Rough, irregular
Color: White matrixes; gray and white clasts
Special Features: Thin glass crusts on some particles
No. of Particles: 16/ Weight: 2.23g

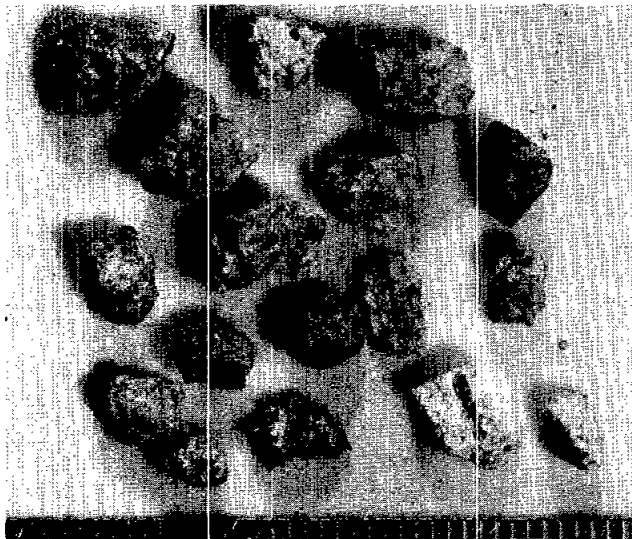

SAMPLE 63504,2

Rock Type: Gray microbreccias; lightly annealed (3b)
Coherence (intergranular): Friable to coherent
Shape: Angular
Surface: Some surfaces coated with brown glass
Color: Matrixes predominantly gray; clasts white
Special Features: None
No. of Particles: 9 / Weight: 2.01g

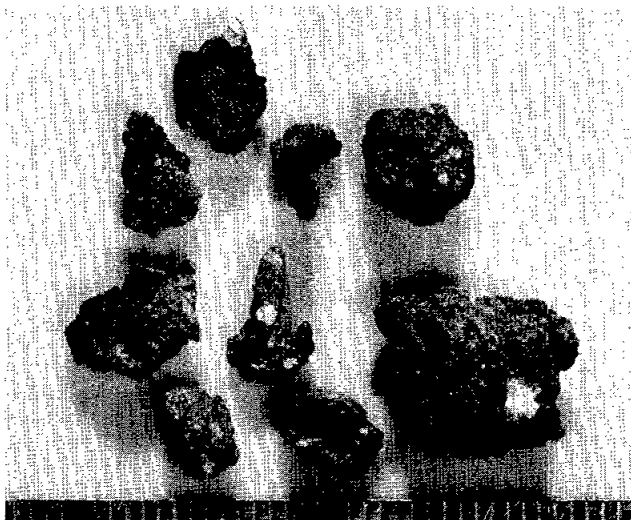

SAMPLE 63504,3

Rock Type: Glassy particles (2)
 Coherence (intergranular): Brittle
 Shape: Irregular to ropy
 Surface: Rough; partially coated with dust and soil
 Color: Light brown to black
 Special Features: Large clast of white microbreccia welded to one
 No. of Particles: 3 / Weight: 0.59g particle

Remarks: The two larger particles are ropy masses of light brown glass coated with fine dust and incorporating fragments of microbreccia; the smallest particle is an irregular fragment of vesicular black glass. All particles are at least partly aphanitic.



SAMPLE 63504,4

Rock Type: Fine-grained crystallines (4)
Coherence (intergranular): Tough
Shape: Angular; blocky to irregular
Surface: Most are smooth; a few sugary or vesicular
Color: Various shades of gray and brown
Special Features: Zap pits on some particles
No. of Particles: 42/ Weight: 8.82g



SAMPLE 63504,5

Rock Type: Anorthositic particles (5b, 5c)
Coherence (intergranular): Friable to coherent
Shape: Angular
Surface: Rough, sugary
Color: White to light gray
Special Features: See Remarks
No. of Particles: 13/ Weight: 2.42g

Remarks: Most of these particles appear to be equigranular crystalline anorthosites. One particle (lower left) is almost wholly coated with pale green to colorless glass. The particle at lower right is translucent; probably devitrified feldspar glass. The large particle at top center is of category 5b; it has angular dark inclusions in a chalky white matrix and appears to have been shocked in situ.



SAMPLE 63504,6

Rock Type: Exceptional particle (7)
Coherence (intergranular): Tough
Shape: Blocky
Surface: Rough, with a few rounded vesicles
Color: Dark brown
Special Features: Zap pits common on one surface
No. of Particles: 1 / Weight: 0.13g

Remarks: This particle is unusual in this collection for its dark brown color and medium-grained crystalline appearance; it may be a mafic rock fragment or a recrystallized glass.



SAMPLE 63324,1

Rock Type: Microbreccia (3b)
Coherence (intergranular): Cohesive; lightly annealed
Shape: Rounded
Surface: Rough; pitted
Color: Matrix light gray; clasts dark and light
Special Features: None
No. of Particles: 1 / Weight: 0.19g



SAMPLE 63324,2

Rock Type: Crystallines; fine-grained to aphanitic (4)
Coherence (intergranular): Coherent except for deep fractures in
Shape: Angular, clumpy larger particle
Surface: Very rough
Color: Mottled; light and dark gray
Special Features: Veinlets of aphanitic material in larger particle
No. of Particles: 2 / Weight: 0.45g

Remarks: These particles have a mottled appearance and irregular shape suggestive of recrystallized glassy microbreccias.



SAMPLE 63324,3

Rock Type: Anorthositic microbreccia (5a)
Coherence (intergranular): Friable; with many small fractures
Shape: Rounded
Surface: Very rough; ribbed with small glassy veinlets
Color: Matrix white; veinlets gray
Special Features: Small patches of glass crust
No. of Particles: 1 / Weight: 0.15g

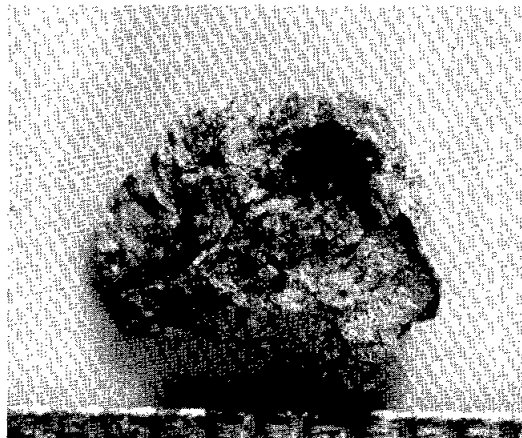

SAMPLE 63324,4

Rock Type: Crystallines (6b,4)
Coherence (intergranular): Tough
Shape: Angular
Surface: One particle relatively smooth; two, vesicular
Color: Speckled gray; brown
Special Features: Sparse zap pits
No. of Particles: 3 / Weight: 0.36g

Remarks: The particle at left is very fine-grained with plagioclase and dark components in a "pepper-and-salt" texture that is almost schistose. The other two are finely crystalline but vesicular; they are probably divitrified glasses.



SAMPLE 63344,1

Rock Type: Metal (7)

No. of Particles: 1 / Weight: 0.22g

Remarks: This unique particle consists of metal globules welded together in a cohesive mass. Some of the globules are deformed to ellipsoids; others appear roughly hexagonal, which may result from crystallization or from close packing. View A shows the "top" surface of the aggregate. Here several globules are coated with rust and the interstices between globules are partially filled with fine dust. View B shows the "underside"; here a number of globules have broken away exposing the interior which is made up of fresh, shiny globules and open pore spaces. Welding scars, where globules have been lost, are present on some of the interior surfaces.

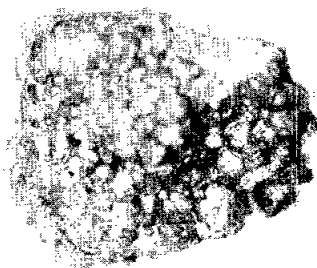
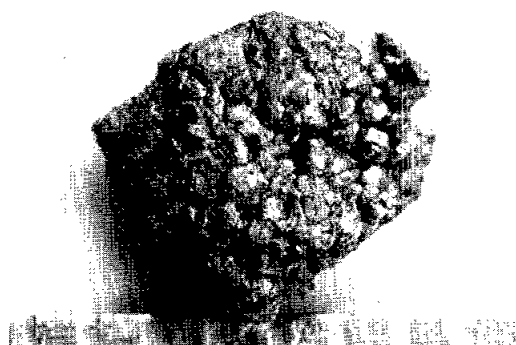

SAMPLE 63344,2

Rock Type: Glassy particle (2)
Coherence (intergranular): Brittle
Shape: Angular
Surface: Mostly smooth but with numerous small vesicles
Color: Dark gray
Special Features: One surface coated with white breccia
No. of Particles: 1 / Weight: 0.43g

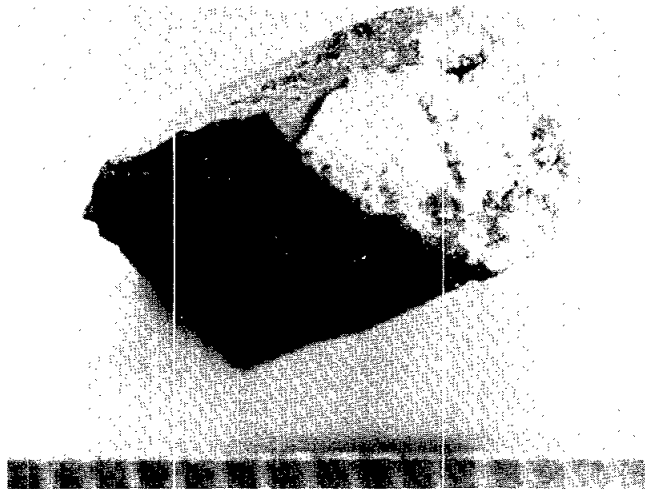

SAMPLE 63344,3

Rock Type: Anorthosites (5c)
Coherence (intergranular): Tough
Shape: Angular to subangular
Surface: Fairly smooth
Color: White to very light gray
Special Features: See Remarks
No. of Particles: 2 / Weight: 0.20g

Remarks: One particle (left) is a tough, angular fragment of fine-grained crystalline plagioclase with tiny specks of metal and sparse grains of a red mineral (spinel?). Zap pits occur on more than one surface.

The particle at right appears to be a fragment of one large crystal of plagioclase coated with white soil.



SAMPLE 63344,4

Rock Type: Gray and white microbreccia (3a)
Coherence (intergranular): Friable; with closely spaced fractures
Shape: Irregular
Surface: Breccia very rough and jagged
Color: Mottled gray and white
Special Features: Dark aphanitic crust on one surface
No. of Particles: 1 / Weight: 0.07g

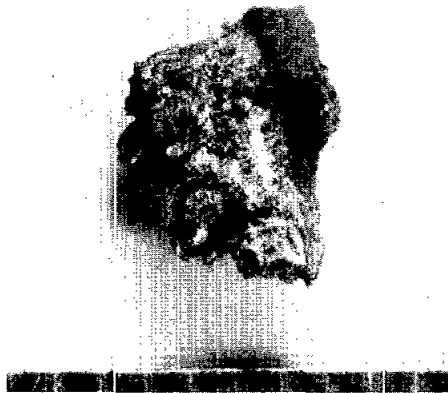

TABLE I. Inventory of Apollo 16 4-10 mm fines.

<u>SAMPLE NUMBER</u>	<u># PAR-TICLES</u>	<u>MASS (g)</u>	<u>ROCK TYPE</u>	<u>SAMPLE LOCATION</u>	<u>PAGE</u>
				<u>Station 1</u>	
				<u>Cayley Pl.</u>	
61144,1	6	0.78	Microbreccias (1a,1b)	Traverse	
61144,2	1	0.52	Gabbroic anorthosite (5d)	"	
61144,3	1	0.29	Varilitic basalt (7) ?	"	
61144,4	14	3.49	Crystallines (4)	"	
61504,1	7	1.69	Microbreccias (1a,1b,1c)	(-15 cm)	
61504,2	6	2.43	Glasses (2)	"	
61504,3	25	5.93	Gabbroic Anorthosite (5d)	"	
61504,4	5	1.01	Anorthosites (5c)	"	
61504,5	3	1.06	Exceptional P. (7)	"	
61164,1	2	0.25	Microbreccias (1a,2)	Plum Cr.Rim	
61164,2	2	0.94	Glasses (2)	"	
61164,3	1	0.12	Gabbroic Anorthosite (5d)	"	
61164,4	5	0.84	Crystallines (4)	"	
61184,1	3	0.70	Microbreccias (1a,1b)	Plum Cr.Rim	
61184,2	2	1.12	Glasses (2)	"	
61184,3	1	0.27	Anorthosite (5b)	"	
61184,4	2	0.10	Anorthosites (5a)	"	
61184,5	6	2.01	Crystallines (4)	"	
61184,6	3	1.86	Anorthosites (5c,5d)	"	
61244,1	18	2.60	Microbreccias (1a,1b)	Trench,top	
61244,2	6	0.67	Glasses (2)	"	
61244,3	23	3.77	Crystallines (4)	"	
61244,4	7	3.10	Anorthosites (5c,5d)	"	
61224,1	6	0.58	Gray microbreccias (1a,3a)	Trench,bot.	
61224,2	1	0.18	Glass (2)	"	
61224,3	12	3.18	Crystallines (4)	"	
61224,4	8	2.31	Gray crystallines (6a)	"	
61224,5	6	0.73	Anorthosites (5c,5d)	"	
61224,6	3	0.34	Microporphyry (7)	"	
61284,1	2	0.14	Microbreccias (1a)	Fillet	
61284,2	2	0.66	Glasses (2)	"	
61284,3	5	0.77	Microbreccias (1a,1c)	"	
61284,4	1	0.04	Anorthosite (5b)	"	
61284,5	8	1.49	Crystallines (4)	"	
61284,6	1	0.34	Gabbroic anorthosite (5d)	"	

TABLE I. (cont.)

<u>SAMPLE NUMBER</u>	<u># PAR-TICLES</u>	<u>MASS (g)</u>	<u>ROCK TYPE</u>	<u>SAMPLE LOCATION</u>	<u>PAGE</u>
				<u>Station 2</u>	
				<u>Cayley Pl.</u>	
62284,1	17	2.03	Microbreccias (1a)	Buster Cr.	
62284,2	5	2.28	Microbreccias (1c)	"	
62284,3	13	1.79	Gray microbreccias (3a,3b)	"	
62284,4	2	0.29	Glasses (2)	"	
62284,5	15	3.00	Crystallines (4)	"	
62284,6	11	2.26	Gray crystallines (6a,6b)	"	
62244,1	48	8.70	Microbreccias (1a)	" ,Rim	
62244,2	7	1.55	Gray microbreccias (3a,3b)	"	
62244,3	4	0.79	Glasses (2)	"	
62244,4	17	3.14	Crystallines (4)	"	
62234,1	4	0.40	Microbreccias (1a)	"	
62234,2	4	0.74	Microbreccias (1c)	"	
62234,3	6	1.39	Glasses (2)	"	
62234,4	10	2.31	Anorthosites (5a)	"	
62234,5	6	3.00	Crystallines (4)	"	
				<u>Station 10</u>	
				<u>Cayley Pl.</u>	
				<u>ALSEP</u>	
60504,1	4	0.22	Anorthosites (5a,5b)	"	
60504,2	22	3.48	Microbreccias (1b,1c)	"	
60504,3	7	1.51	Crystallines (4)	"	
60504,4	6	1.01	Microbreccias (1c)	"	
60054,1	1	0.22	Microbreccia (1a)	"	
60054,2	1	0.30	Glass (2)	"	
60054,3	10	3.00	Anorthosites (5a)	"	
60054,4	2	0.42	Gray microbreccias (3b)	"	
60054,5	14	2.40	Crystallines (4)	"	
60604,1	13	1.15	Microbreccias (1a,1b,1c)	"	
60604,2	3	0.61	Gray crystallines (6a)	"	
60604,3	3	0.54	Glass (2)	"	
60604,4	7	1.37	Crystallines (4)	"	
				<u>Station 4</u>	
				<u>Stone Mt.</u>	
64504,1	20	4.16	Microbreccias (1a)	15-m Cr.,rim	
64504,2	19	4.39	Gray microbreccias (3a,3b)	"	
64504,3	9	2.12	Gray microbreccias (3b)	"	
64504,4	23	4.41	Crystallines (4)	"	
64504,5	22	3.47	Anorthosites (5a,5c)	"	
64504,6	5	1.05	Exceptional (7)	"	
64504,7	4	1.52	Anorthosites (5c,5d)	"	

TABLE I. (cont.)

<u>SAMPLE NUMBER</u>	<u># PAR- TICLES</u>	<u>MASS (g)</u>	<u>ROCK TYPE</u>	<u>SAMPLE LOCATION</u>	<u>PAGE</u>
				<u>Station 4</u>	
				<u>Stone Mt.</u>	
				Trench	
64424,1	3	0.29	Microbreccias (1a)	"	
64424,2	2	0.68	Anorthosites (5b)	"	
64424,3	1	0.15	Microbreccia (1c)	"	
64424,4	4	0.64	Crystallines (4)	"	
64424,5	1	0.04	Exceptional (7)	"	
64814,1	5	0.77	Microbreccias (1a,1c)	20-m Cr.,rim	
64814,2	1	0.12	Glass (2)	"	
64814,3	8	1.59	Crystallines (4)	"	
64814,4	1	0.16	Gabbroic anorthosite(5d)	"	
64804,1	12	1.83	Microbreccias (1a,1b,1c)	"	
64804,2	14	2.93	Gray microbreccias (3b)	"	
64804,3	4	1.04	Anorthosites (5d)	"	
64804,4	2	0.29	Anorthosites (5c)	"	
			(undusted)		
65504,1	2	0.99	Microbreccias (1b)	20-m Cr.,rim	
65504,2	6	2.04	Gray microbreccias (3a)	"	
65504,3	2	0.54	Crystallines (4)	"	
65504,4	>	16.77	Friable clods	"	
65704,1	2	0.83	Gray microbreccia (3a)	"	
65704,2	1	0.17	Gabbroic anorthosite (5d)	"	
65704,3	1	0.11	Gray microbreccia (3b)	"	
65904,1	24	3.12	Microbreccias (1a,1b)	15 cm depth	
65904,2	1	0.31	Glass (2)	"	
65904,3	11	3.01	Gray microbreccias (3b)	"	
65904,4	9	2.13	Crystallines (4)	"	
65904,5	2	0.28	Gabbroic anorthosites (5d)"	"	
				<u>Station 6</u>	
				<u>Stone Mt.</u>	
66034,1	1	1.07	Microbreccias (1c)	10-m Cr.,rim	
66034,2	4	2.16	Microbreccias (3a)	"	
			(undusted)		
66044,1	13	3.13	Glasses (2)	"	
66044,2	15	3.09	Microbreccias (1a,1b)	"	
66044,3	21	2.64	Anorthosites (5a)	"	
66044,4	3	0.42	Crystallines (4)	"	
66044,5	2	0.70	Anorthosites (5a,5c)	"	

TABLE I. (cont.)

<u>SAMPLE NUMBER</u>	<u># PAR- TICLES</u>	<u>MASS (g)</u>	<u>ROCK TYPE</u>	<u>SAMPLE LOCATION</u>	<u>PAGE</u>
				<u>Station 6</u>	
(undusted)				Stone Mt.	
66084,1	4	0.42	Microbreccias (1a,1b)	White patch	
66084,2	5	0.96	Crystallines (4)	"	
66084,3	5	0.68	Gray microbreccias (3a,3b)	"	
				<u>Station 8</u>	
				S. Ray Cr.	
68504,1	12	1.20	Microbreccia (1a,1b)	Ejecta dep.	
68504,2	3	1.10	Glasses (2)	"	
68504,3	25	5.10	Crystallines (4)	"	
68504,4	19	6.14	Crystallines (4)	"	
68504,5	6	1.26	Anorthosites (5c)	"	
68504,6	4	1.33	Exceptional P. (7)	"	
(undusted)					
68124,1	6	0.44	Microbreccias (1a,1b)	"	
68124,2	5	1.24	Gray microbreccias (3b)	"	
68124,3	2	0.28	Glass (spherules) (2)	"	
68124,4	13	4.57	Crystallines (4)	"	
68124,5	2	0.33	Glasses (2)	"	
68124,6	5	0.80	Gray crystallines (6a)	"	
68124,7	2	0.51	Anorthosites (5a,5c)	"	
68844,1	13	1.56	Microbreccias (1a,1b,1c)	Ref. soil	
68844,2	10	2.21	Crystallines (4)	"	
68844,3	6	0.66	Anorthosites (5c)	"	
68844,4	2	0.28	Exceptional (7)	"	
68824,1	1	0.16	Anorthosite (5a)	Fillet	
68824,2	3	0.41	Glasses (2)	"	
68824,3	3	0.59	Crystallines (3b)	"	
68824,4	1	0.12	Exceptional (7)	"	
68824,5	1	0.18	Anorthosite (5c)	"	
				<u>Station 9</u>	
				S. Ray Cr.	
69924,1	9	0.41	Microbreccias (1a,1b)	S. rim soil	
69924,2	1	0.09	Gray microbreccia (3a)	"	
69924,3	1	0.08	Glass (2)	"	
69924,4	1	0.15	Anorthosite (5c)	"	
69924,5	2	0.15	Crystallines (4)	"	

TABLE I. (cont.)

<u>SAMPLE NUMBER</u>	<u># PAR-TICLES</u>	<u>MASS (g)</u>	<u>ROCK TYPE</u>	<u>SAMPLE LOCATION</u>	<u>PAGE</u>
				<u>Station 9</u>	
				<u>S. Ray Cr.</u>	
69944,1	5	0.41	Microbreccias (1a,1b,1c)	Scoop soil	
69944,2	3	0.40	Gray microbreccias (3a)	"	
69944,3	11	1.63	Glasses (2)	"	
69944,4	6	1.03	Crystallines (4)	"	
69944,5	1	0.12	Anorthosite (5c)	"	
69944,6	2	0.43	Gray microbreccias (3b)	"	
69964,1	2	0.53	Glasses (2)	Under	
69964,2	2	0.70	Anorthosites (5c)	boulder	
69964,3	3	0.37	Microbreccias (1a,1c)	"	
69964,4	5	1.02	Crystallines (4)	"	
69964,5	4	0.98	Glass-rich (2)	"	
				<u>Station 11</u>	
				<u>N. Ray Cr.</u>	
67704,1	2	0.29	Glasses (2)	Rim; white	
67704,2	14	2.17	Gray microbreccias (3a,3b)	"	
67704,3	15	1.98	Crystallines (4)	"	
67704,4	1	0.14	Anorthosite (5c)	"	
67714,1	5	0.26	Microbreccia (1a)	SE Rim	
67714,2	8	1.07	Gray microbreccias (3b)	"	
67714,3	6	0.81	Anorthosites (5c)	"	
67714,4	11	3.38	Gray microbreccias (3b)	"	
67714,5	21	5.44	Crystallines (4)	"	
67484,1	8	1.14	Glasses (2)	S. Rim	
67484,2	9	1.48	Crystallines (4)	Ref. soil	
67484,3	7	0.54	Anorthosites (5a)	"	
67484,4	4	0.95	Anorthosites (5a,5c)	"	
67514,1	60	15.17	Gray microbreccias (3a)	S. Rim	
67514,2	13	3.32	Anorthosite (5a)	"	
67514,3	10	2.63	Crystallines (4)	"	
67514,4	14	2.63	Anorthosites (5b,5c)	"	
67514,5	1	0.15	Gabbroic anorthosite (5d)	"	
67514,6	1	0.09	Crystallines (5c)	"	
67464,1	2	0.15	Glasses (2)	Fillet	
67464,2	2	0.23	Gray microbreccias (3b)	"	
67464,3	1	0.10	Crystalline (4)	"	
67464,4	1	0.17	Gray microbreccia (3b)	"	

TABLE I. (cont.)

<u>SAMPLE NUMBER</u>	<u># PAR-TICLES</u>	<u>MASS (g)</u>	<u>ROCK TYPE</u>	<u>SAMPLE LOCATION</u>	<u>PAGE</u>
67604,1	4	1.62	Anorthosites (5c)	Rim	
67604,2	3	0.94	Gray microbreccias (3a)	"	
67944,1	13	4.65	Crystallines (4)	House Rk.	
67944,2	8	2.06	Gray crystallines (6b)	E-W split	
67944,3	2	0.66	Glasses (2)	"	
67944,4	2	0.67	Gray microbreccias (3b,5a)	"	
67944,5	2	0.30	Gabbroic anorthosites (5d)	"	
				<u>Station 13</u>	
				<u>N. Ray Cr.</u>	
63504,1	16	2.23	Gray microbreccia (3a,3b)	Regolith	
63504,2	9	2.01	Gray microbreccias (3b)	"	
63504,3	3	0.59	Glasses (2)	"	
63504,4	42	8.82	Crystallines (4)	"	
63504,5	13	2.42	Anorthosites (5b,5c)	"	
63504,6	1	0.13	Exceptional P. (7)	"	
				<u>Shadow</u>	
63324,1	1	0.19	Gray microbreccia (3b)	rock	
63324,2	2	0.45	Crystalline (4)	"	
63324,3	1	0.15	Anorthosite (5a)	"	
63324,4	3	0.36	Crystallines (6b,4)	"	
63344,1	1	0.22	Metal (7)	"	
63344,2	1	0.43	Glass (2)	"	
63344,3	2	0.20	Anorthosites (5c)	"	
63344,4	1	0.07	Gray microbreccia (3a)	"	

Acknowledgements and Caveat

I wish to thank the staff members operating the nitrogen lines at the Lunar Receiving Laboratory for their indispensable help, offered with unfailing courtesy and good humor, in carrying out this project. In a minimum amount of time each sample was opened, dusted, handpicked, described, photographed, weighed, and returned to separate containers for storage. All of these operations except the handpicking and describing were done by the staff members. I also wish to thank the members of the curator's office who provided much aid and assistance during the investigations and who finally guided the catalogue through the press.

Catalogue users should be aware that separating the particles into groups required subjective judgements made quickly and irrevocably. No opportunity existed for re-checking samples viewed earlier and reclassifying them in the light of new observations. The gradational nature of several of the rock types and the method of study combined to produce a certain amount of overlap in the picked fractions.

This project was supported in part by NASA Grant NGL-09-015-150.

References

Interagency Report: Astrogeology 51. Documentation and environment of the Apollo 16 samples: A preliminary report. Apollo Lunar Geology Investigation Team, U.S. Geological Survey. May 26, 1972

Lunar Sample Information Catalog: Apollo 16. MSC 03210 Manned Spacecraft Center, July 1972